

NO	DESCRIPTION	MATERIAL	Q'TY	FINISH	REMARK
1	PIN	BE CU	1	GOLD	P-SMA0635-G
2	BODY 1	BRASS	1	NICKEL	B-SMA0235-N
3	NUT 1	BRASS	1	GOLD	N-0020-G
4	INSULATION 1	TEFLON	1	TEFLON	I-0047T
5	BODY 2	BRASS	1	NICKEL	B-SMA0232-N
6	INSULATION 2	TEFLON	1	TEFLON	I-0046T
7	WASHER	BRASS	1	GOLD	W-0016
8	NUT 2	BRASS	1	NICKEL	N-0006-N
9	RING	BRASS	NICKEL	R-0022-N	

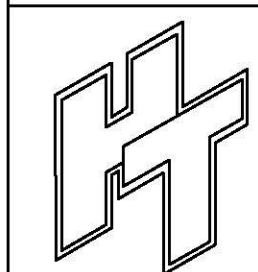
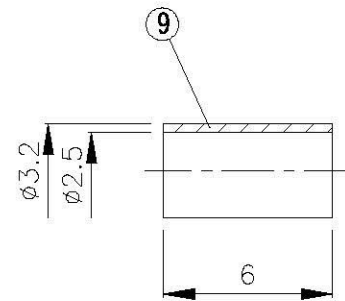
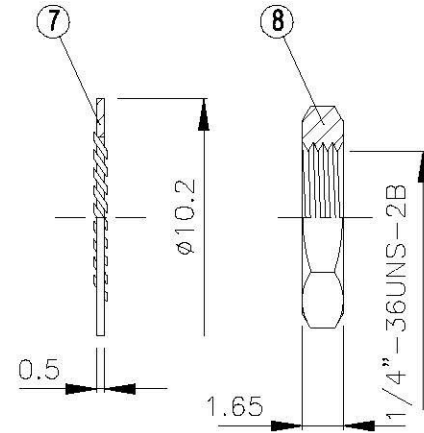
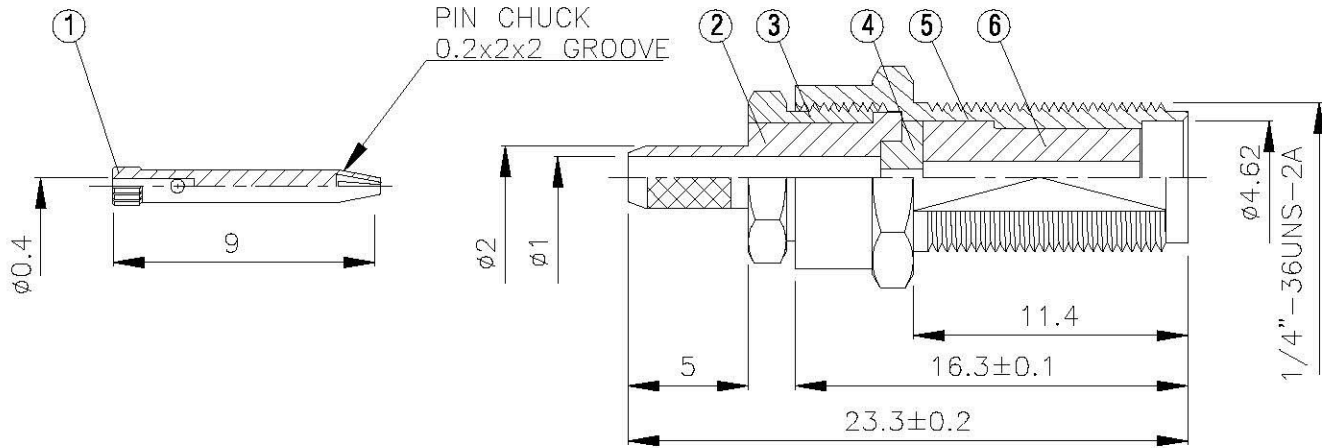
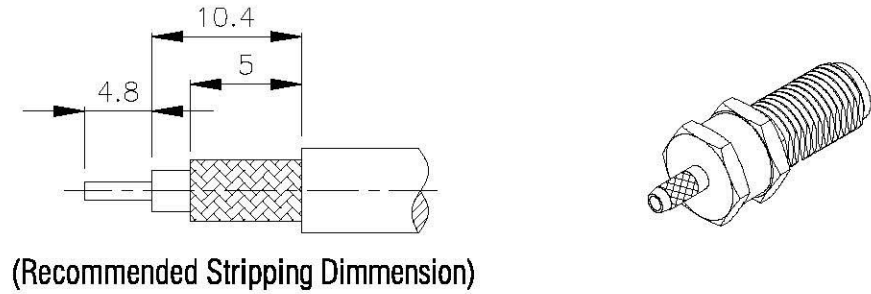

All Connectors
 www.allconnectors.com
 30720 Fichtelbergstr. • Germany

TITLE SMA FEMALE CRIMP FOR RG178/U

PART NO. SMA-44M-TGN

DRAWING NO. SMA 44M TGN

DRAWN 蘇姿潔 **DATE** 98.12.07

CHECKED 蘇志欣 **DATE**

Q.A. 林妙樺 **DATE**

APPROVAL 徐燦霖 **DATE**

REVISION **DATE**

DIMENSIONS ARE IN MILLIMETERS

UNLESS OTHERWISE SPECIFIED TOLERANCE

0.5-5=±0.2 120-315=±1

5-30=±0.4 315-1000=±1.6

30-120±0.6 1000-2000=±2.4

SCALE 4:1 **SIZE** A

REVISION	
DESCRIPTION	ENGINEER