

NO	DESCRIPTION	MATERIAL	Q'TY	FINISH	REMARK
1	COUPLING NUT	ST STEEL	1	PASSIVATED	B-SMA0043-SUS
2	GASKET	SI RUBBER	1	RUBBER	RU-0008
3	INSULATION	TEFLON	1	TEFLON	I-0491T
4	WASHER	SUS303	1	NICKEL	W-0012
5	BODY	ST STEEL	1	PASSIVATED	B-SMA1007-SUS
6	PIN	PH.BRONZE	1	GOLD	P-SMA0701-G

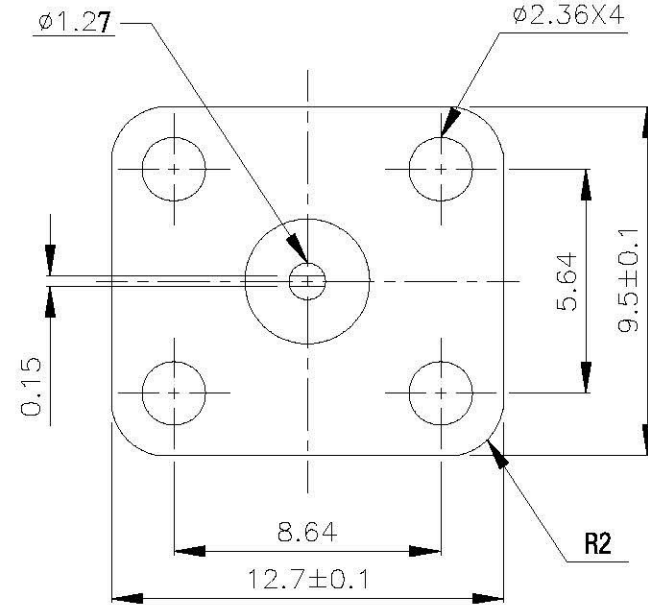
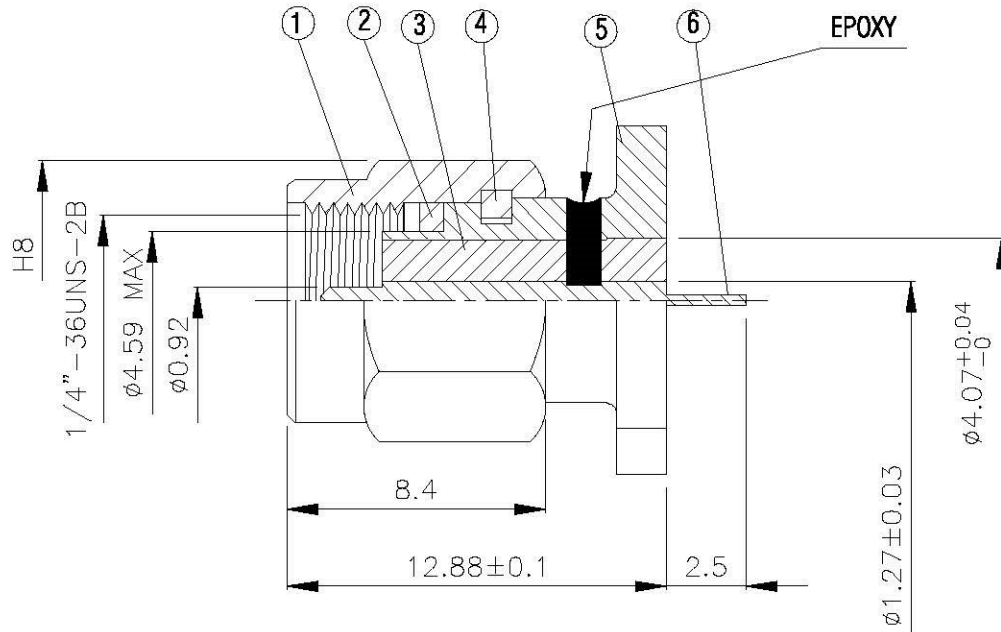
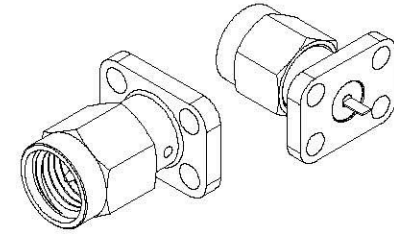

		DRAWN	MARY	DATE	94.09.28	DIMENSIONS ARE IN MILLIMETERS			REVISION				
	<small>www.allconnectors.biz tel: 0012 733 7002002 25754 Fildes Court - Germany</small>	<small>info@allconnectors.biz fax: 0012 733 7002091 02 Germany, 35</small>	CHECKED	沈佳德	DATE						94.09.28	UNLESS OTHERWISE SPECIFIED TOLERANCE	
	TITLE		Q.A.	蘇姿潔	DATE		0.5-5=±0.2	120-315=±1					
	PART NO.		APPROVAL	徐燦霖	DATE		5-30=±0.4	315-1000=±1.6					
	DRAWING NO.		REVISION		DATE		30-120±0.6	1000-2000=±2.4					
SMA-33V9-TGSUS						SCALE	4:1	SIZE	A				