

NO	DESCRIPTION	MATERIAL	Q'TY	FINISH	REMARK
1	SHELL	BRASS	1	NICKEL	B-SMA0043-G
2	GASKET	SI RUBBER	1	RUBBER	RU-0008
3	INSULATION	TEFLON	1	TEFLON	I-0132T
4	WASHER	PH.BRONZE	1	NICKEL	W-0012
5	BODY	BRASS	1	NICKEL	B-SMA0095-G
6	PIN	BRASS	1	GOLD	P-SMA0062-G

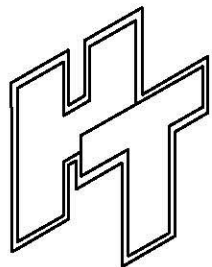
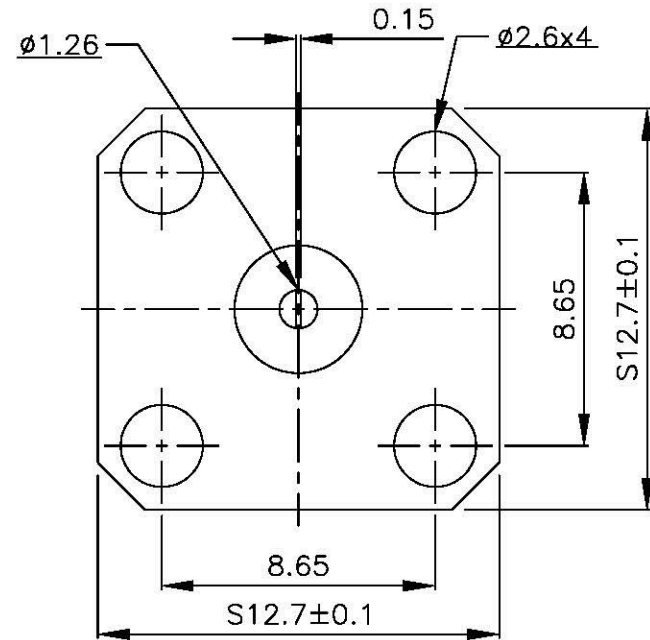
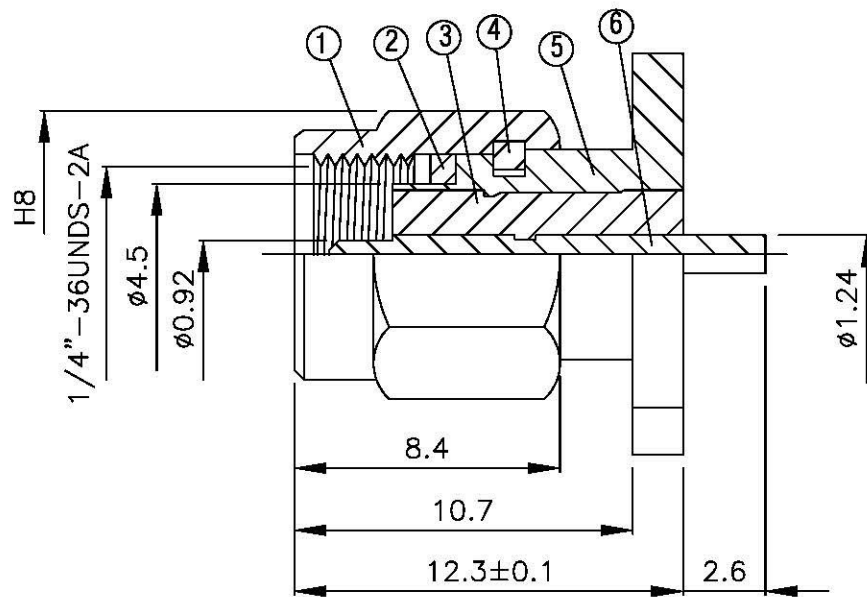
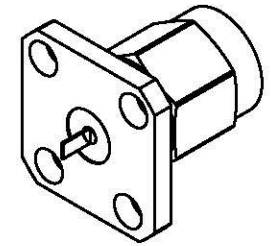

All Connectors

www.allconnectors.com
 Tel: 6648 711 7009208
 70784 Plover Road, Gohmway

allconnectors.com
 Fax: 6648 711 7009204
 Kertomacstr. 25

TITLE
SMA MALE PANEL RECEPTACLE

PART NO.
SMA-33V5-TGN

DRAWING NO.
SMA 33V5 TGN

DRAWN MARY DATE 96.03.16

CHECKED 黄巧君 DATE

Q.A. 蘇姿潔 DATE

APPROVAL 徐燦霖 DATE

REVISION DATE

DIMENSIONS ARE IN MILLIMETERS

UNLESS OTHERWISE SPECIFIED
 TOLERANCE

0.5-5 = ± 0.2 120-315 = ± 1

5-30 = ± 0.4 315-1000 = ± 1.6

30-120 = ± 0.6 1000-2000 = ± 2.4

SCALE 4:1 SIZE A

REVISION

DESCRIPTION ENGINEER