

NO	DESCRIPTION	MATERIAL	Q'TY	FINISH	REMARK
1	SHELL	BRASS	1	GOLD	B-SMA0043-G
2	GASKET	SI RUBBER	1	RUBBER	RU-0008
3	INSULATION	TEFLON	1	TEFLON	I-0235T
4	WASHER	PH.BRONZE	1	GOLD	W-0012
5	BODY	BRASS	1	GOLD	B-SMA0102-G
6	PIN	BRASS	1	GOLD	P-SMA0095-G

**All Connectors**

www.allconnectors.de  
Tel.: 0049 711 7009503  
70794 Filderstadt - Germany

info@allconnectors.de  
Fax: 0049 711 7009504  
Kettnerstr. 25

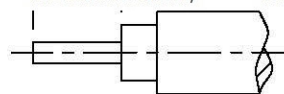

(Recommended Stripping Dimension)

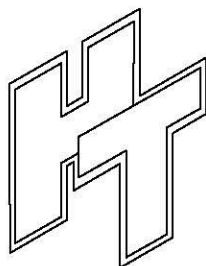
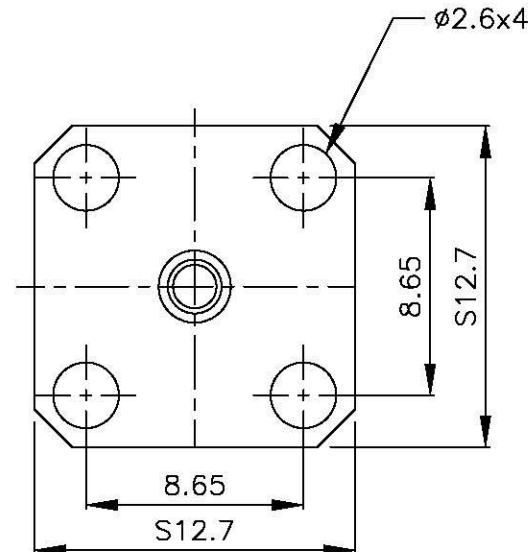
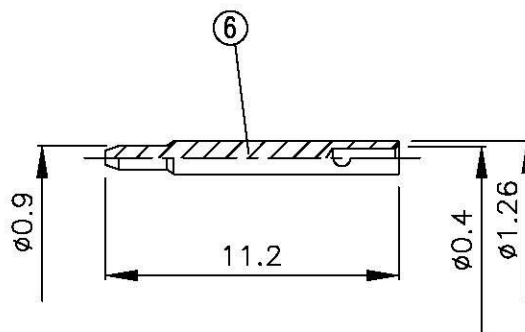
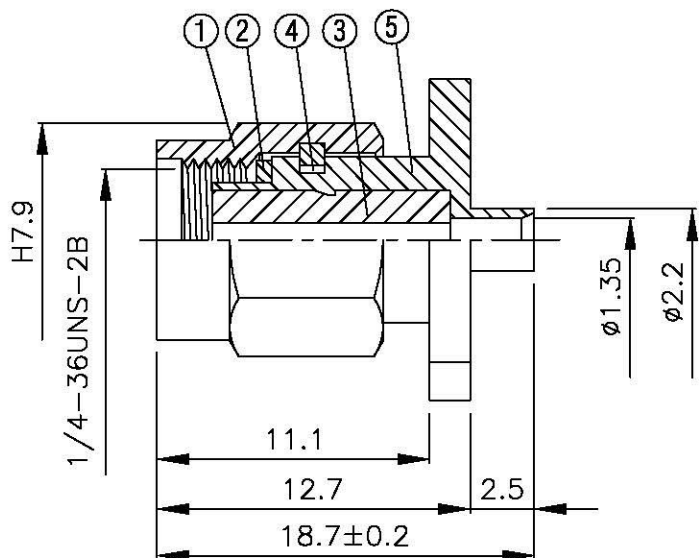
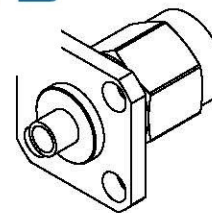

**All Connectors**

www.allconnectors.de info@allconnectors.de  
Tel.: 0049 711 7009503 Fax: 0049 711 7009504  
70794 Filderstadt - Germany Kettnerstr. 25

TITLE SMA MALE PANEL SOLDER FOR M17/151 (.047)

PART NO. SMA-33V3-TGG

DRAWING NO. SMA 33V3 TGG

DRAWN MARY DATE 96.03.15

CHECKED 蘇姿潔 DATE

Q.A. 馮健華 DATE

APPROVAL 徐燦霖 DATE

REVISION DATE

DIMENSIONS ARE IN MILLIMETERS

UNLESS OTHERWISE SPECIFIED TOLERANCE

0.5-5=±0.2	120-315=±1
5-30=±0.4	315-1000=±1.6
30-120±0.6	1000-2000=±2.4

SCALE 4:1 SIZE A

REVISION

DESCRIPTION	ENGINEER