

NO	DESCRIPTION	MATERIAL	Q'TY	FINISH	REMARK
1	SHELL	BRASS	1	GOLD	B-SMA0043-G
2	GASKET	SI RUBBER	1	RUBBER	RU-0008
3	INSULATION	TEFLON	1	TEFLON	I-0235T
4	WASHER	PH.BRONZE	1	GOLD	W-0012
5	BODY	BRASS	1	GOLD	B-SMA0101-G
6	PIN	BRASS	1	GOLD	P-SMA0058-G

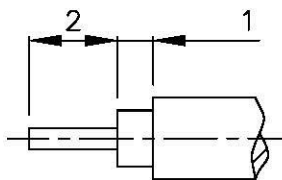

(Recommended Stripping Dimension)

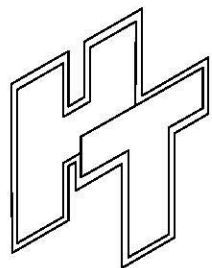
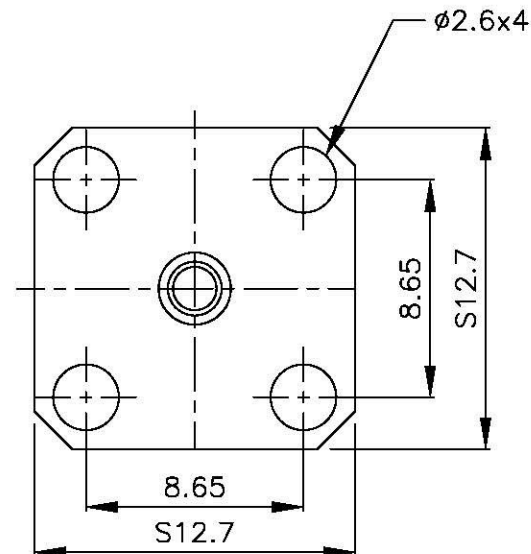
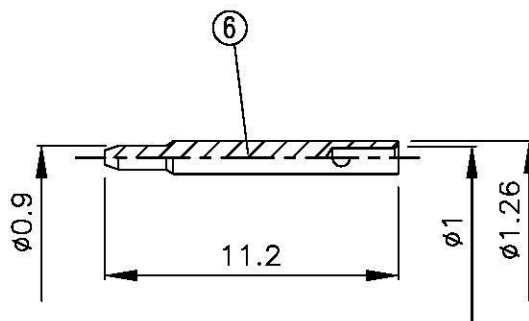
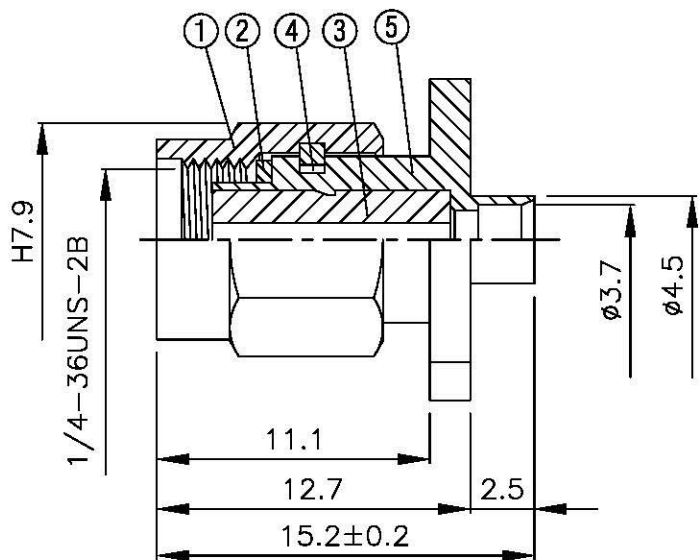
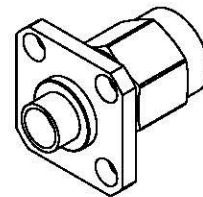

All Connectors

www.allconnectors.com
 TEL: 0215 711 7035/33
 33296 Pitters Hill, Germany
 info@allconnectors.com
 Fax: 0219 711 7035/301
 Krefeld, Germany

TITLE SMA MALE PANEL SOLDER FOR
 RG 402/U (.141)

PART NO. SMA-33V2-TGG

DRAWING NO. SMA 33V2 TGG

DRAWN MARY DATE 96.03.15

CHECKED 蘇姿潔 DATE

Q.A. 馮健華 DATE

APPROVAL 徐燦霖 DATE

REVISION DATE

DIMENSIONS ARE IN MILLIMETERS

UNLESS OTHERWISE SPECIFIED
 TOLERANCE
 0.5-5=±0.2 120-315=±1
 5-30=±0.4 315-1000=±1.6
 30-120±0.6 1000-2000=±2.4

SCALE 4:1 SIZE A

REVISION

DESCRIPTION ENGINEER