

NO	DESCRIPTION	MATERIAL	Q'TY	FINISH	REMARK
1	SHELL	BRASS	1	GOLD	B-SMA0043-G
2	GASKET	SI RUBBER	1	RUBBER	RU-0008
3	INSULATION	TEFLON	1	TEFLON	I-0235T
4	WASHER	PH.BRONZE	1	GOLD	W-0012
5	BODY	BRASS	1	GOLD	B-SMA0100-G
6	PIN	BRASS	1	GOLD	P-SMA0059-G

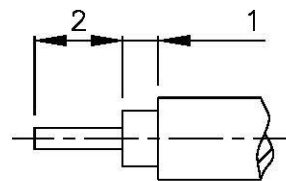

(Recommended Stripping Dimension)

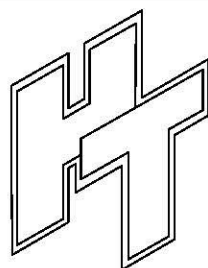
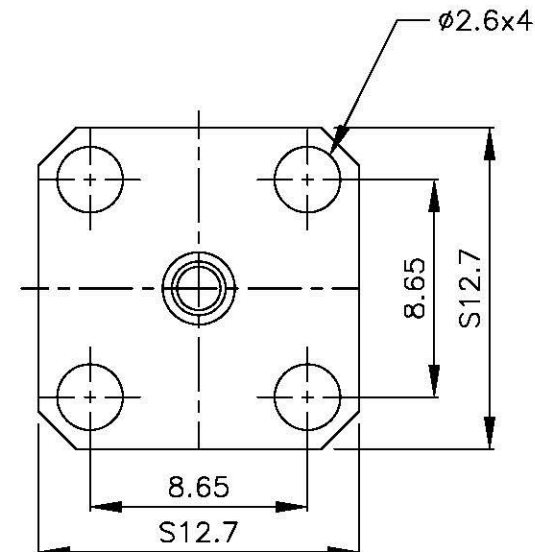
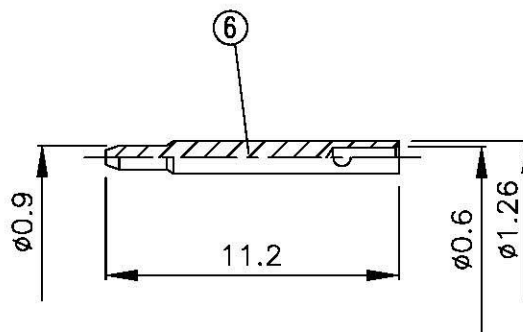
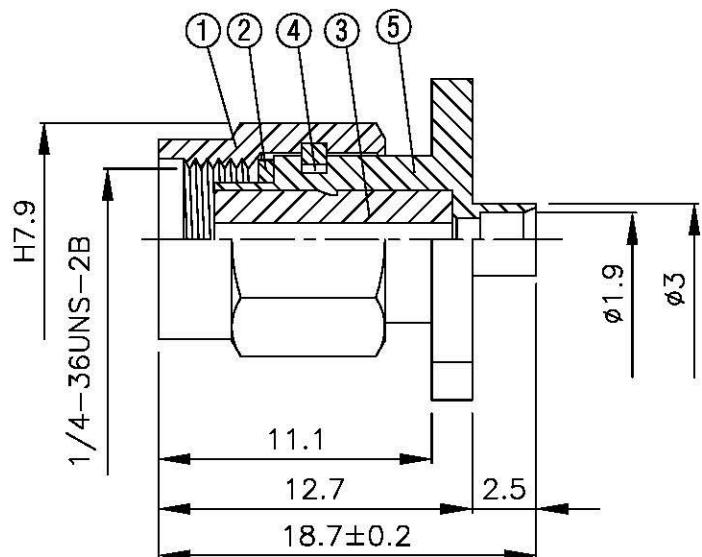
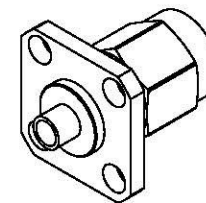

All Connectors

www.allconnectors.de
Tel: 0049 721 200980
72774 Hildersheim - Germany

Info@allconnectors.de
Fax: 0049 721 200981
Kontakt@ac.de

TITLE SMA MALE PANEL SOLDER
FOR RG 405/U (.085)

PART NO. SMA-33V1-TGG

DRAWING NO. SMA 33V1 TGG

DRAWN MARY DATE 90.01.25

CHECKED 蘇姿潔 DATE

Q.A. 馮健華 DATE

APPROVAL 徐燦霖 DATE

REVISION DATE

DIMENSIONS ARE IN MILLIMETERS

UNLESS OTHERWISE SPECIFIED
TOLERANCE

0.5-5=±0.2	120-315=±1
5-30=±0.4	315-1000=±1.6
30-120±0.6	1000-2000=±2.4

SCALE 4:1 SIZE A

REVISION

DESCRIPTION	ENGINEER