

NO	DESCRIPTION	MATERIAL	Q'TY	FINISH	REMARK
1	SHELL	BRASS	1	GOLD	B-SMA0043-G
2	GASKET	SI RUBBER	1	RUBBER	RU-0008
3	INSULATION	TEFLON	1	TEFLON	I-0235T
4	WASHER	PH.BRONZE	1	GOLD	W-0012
5	BODY	BRASS	1	GOLD	B-SMA0098-G
6	PIN	BRASS	1	GOLD	P-SMA0059-G
7	RING	BRASS	1	GOLD	R-0002-G

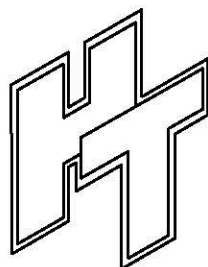
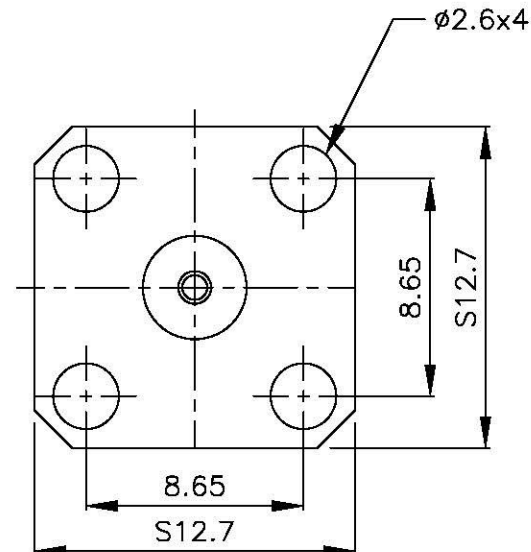
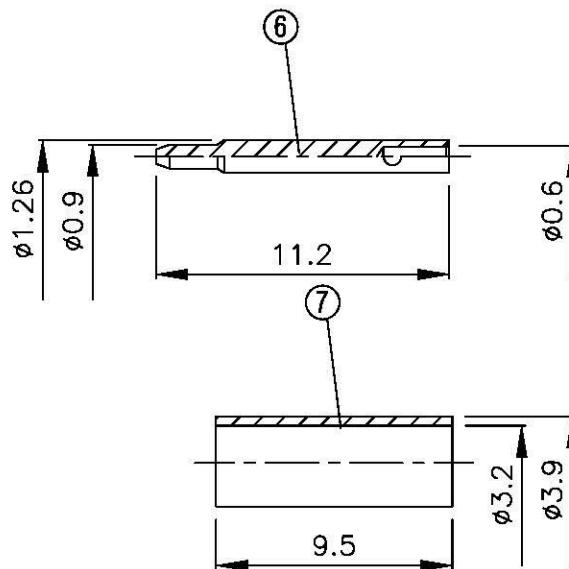
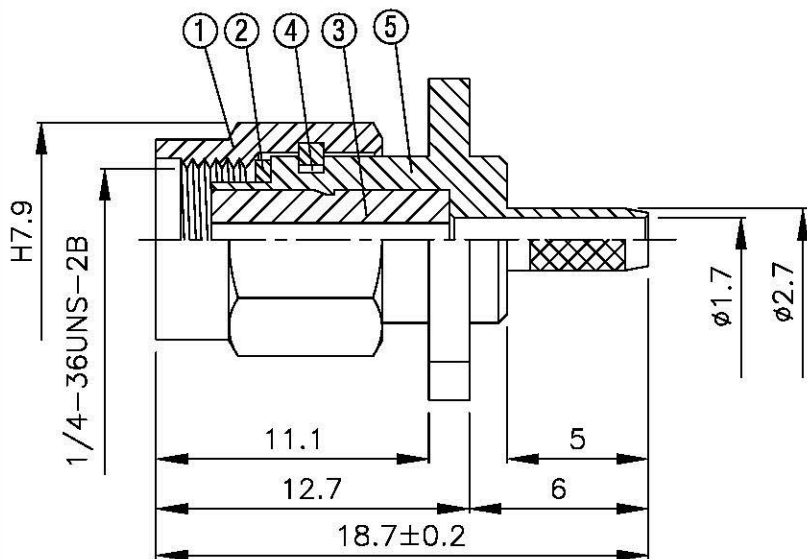
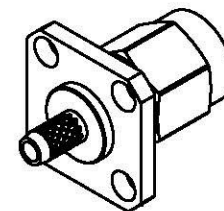
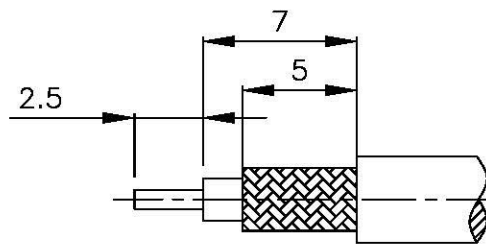

All Connectors
 www.allconnectors.de info@allconnectors.de
 Tel.: 0049 711 790280 Fax: 0049 711 7909501
 4054 Hildebrandt Germany Kettelerstr. 25

TITLE SMA MALE PANEL CRIMP
 FOR RG 174/U

PART NO. SMA-33LV1-TGG

DRAWING NO. SMA 33LV1 TGG

DRAWN	MARY	DATE	96.03.15
CHECKED	蘇姿潔	DATE	
Q.A.	馮健華	DATE	
APPROVAL	徐燦霖	DATE	
REVISION		DATE	

DIMENSIONS ARE IN MILLIMETERS			
UNLESS OTHERWISE SPECIFIED TOLERANCE			
0.5-5=±0.2	120-315=±1		
5-30=±0.4	315-1000=±1.6		
30-120±0.6	1000-2000=±2.4		
SCALE	4:1	SIZE	A

REVISION	
DESCRIPTION	ENGINEER