

NO	DESCRIPTION	MATERIAL	Q'TY	FINISH	REMARK
1	SHELL	BRASS	1	GOLD	B-SMA0043-G
2	GASKET	SI RUBBER	1	RUBBER	RU-0008
3	INSULATION	TEFLON	1	TEFLON	I-0235T
4	WASHER	PH.BRONZE	1	GOLD	W-0012
5	BODY	BRASS	1	GOLD	B-SMA0099-G
6	PIN	BRASS	1	GOLD	P-SMA0058-G
7	RING	BRASS	1	GOLD	R-0007-G

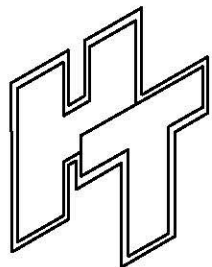
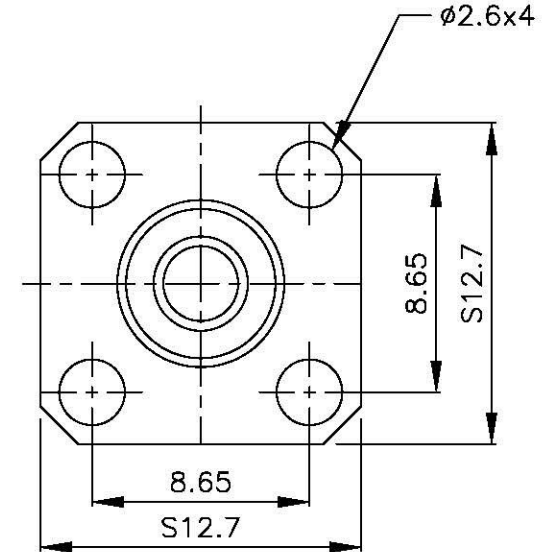
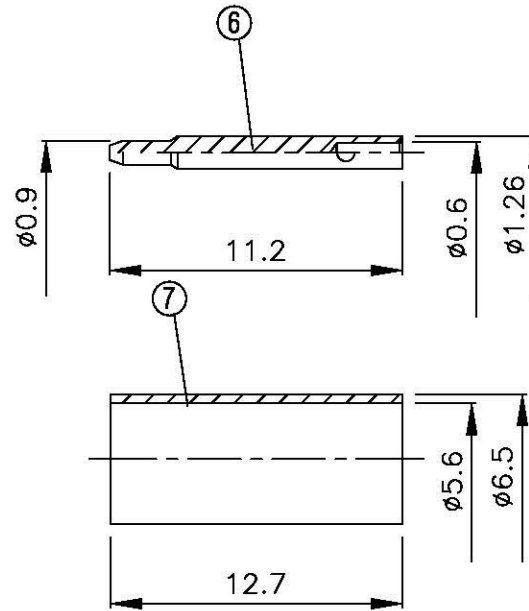
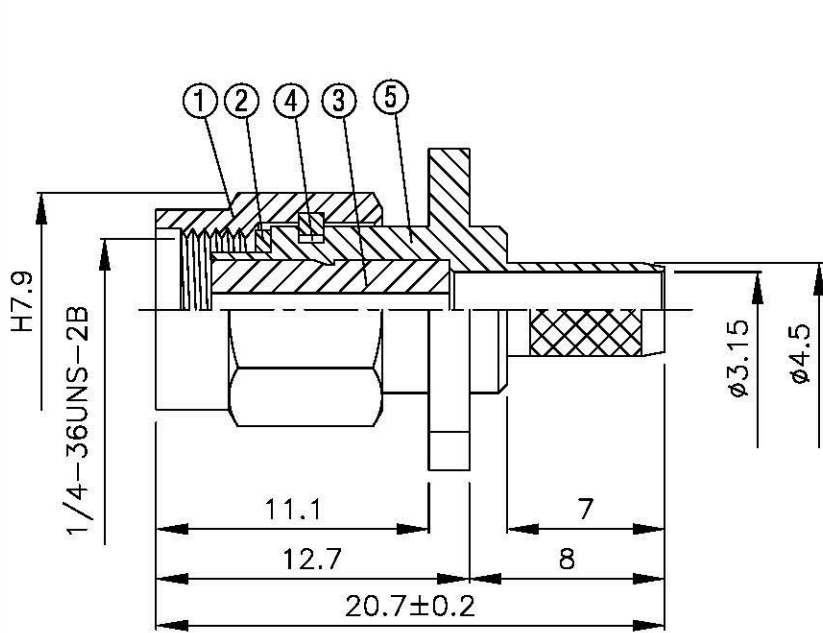
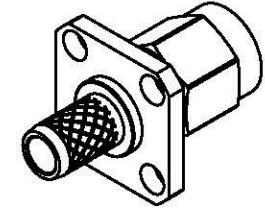
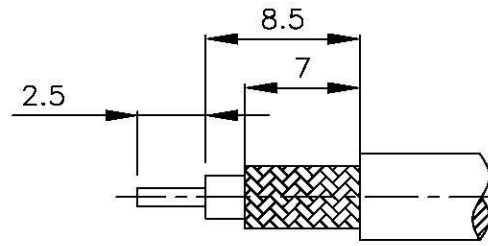

All Connectors
 www.allconnectors.de
 info@allconnectors.de
 Tel: 0049 711 709953
 20784 Ellerdorf, Germany
 Fax: 0049 711 709 504
 Kottbuserstr. 27

TITLE SMA MALE PANEL CRIMP FOR RG 58/U
 PART NO. SMA-33F-TGG
 DRAWING NO. SMA 33F TGG

DRAWN MARY DATE 96.03.15
 CHECKED 蘇姿潔 DATE
 Q.A. 馮健華 DATE
 APPROVAL 徐燦霖 DATE
 REVISION DATE

DIMENSIONS ARE IN MILLIMETERS
 UNLESS OTHERWISE SPECIFIED TOLERANCE
 0.5-5=±0.2 120-315=±1
 5-30=±0.4 315-1000=±1.6
 30-120±0.6 1000-2000=±2.4
 SCALE 4:1 SIZE A

REVISION	
DESCRIPTION	ENGINEER