

NO	DESCRIPTION	MATERIAL	Q'TY	FINISH	REMARK
1	BODY 1	BRASS	1	NICKEL	B-SMA0317-N
2	PIN	BE CU	1	GOLD	P-SMA0252-G
3	INSULATION	TEFLON	1	TEFLON	I-0186T
4	BODY 2	BRASS	1	NICKEL	B-SMA0400-N
5	INSULATION	TEFLON	1	TEFLON	I-0151T

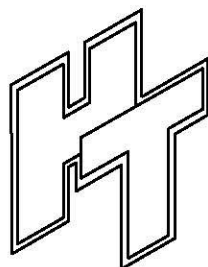
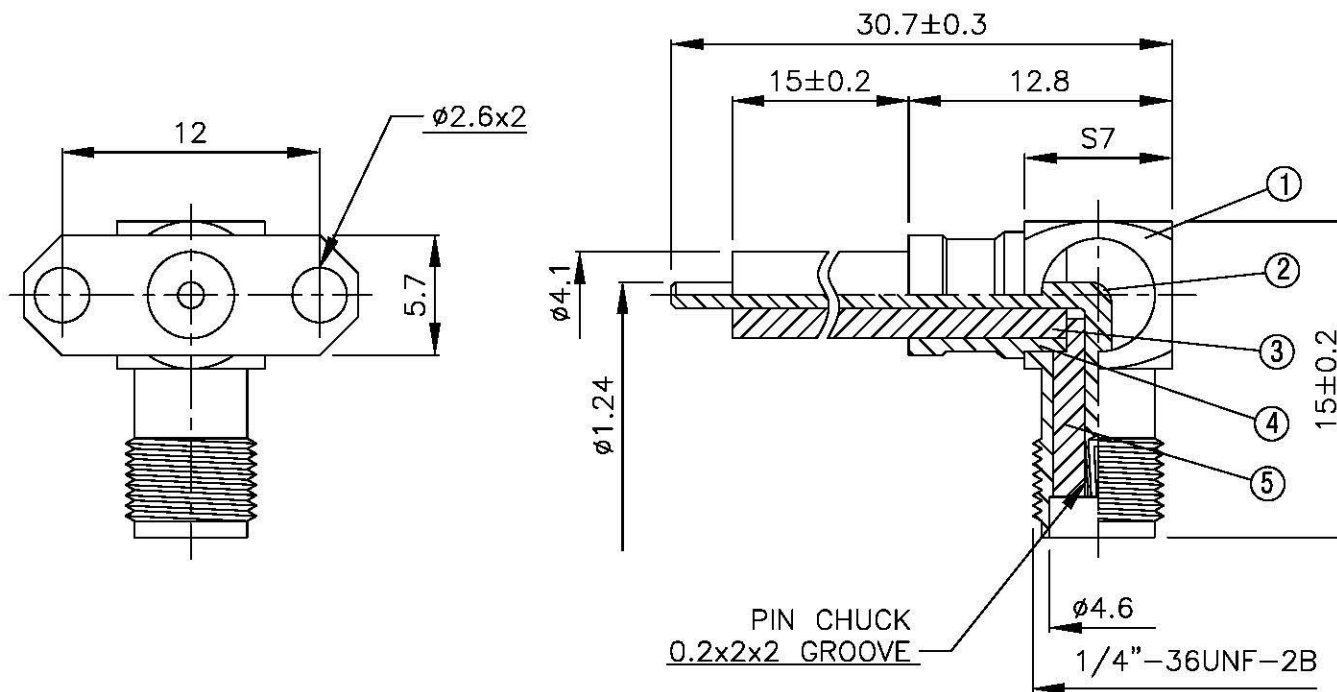
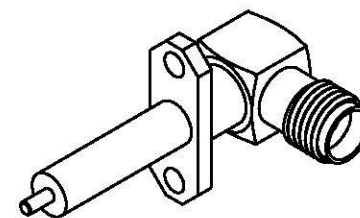

All Connectors
 www.allconnectors.com
 Tel: +0049 711 7049508
 70704 Milsenstedt - Germany

TITLE SMA RIGHT ANGLE JACK 2 HOLES FLANGE MOUNT

PART NO. SMA-31-TGN

DRAWING NO. SMA 31 TGN

DRAWN MARY DATE 96.03.15

CHECKED 黄巧君 DATE

Q.A. 蘇姿潔 DATE

APPROVAL 徐燦霖 DATE

REVISION DATE

DIMENSIONS ARE IN MILLIMETERS

UNLESS OTHERWISE SPECIFIED TOLERANCE
 0.5-5=±0.2 120-315=±1
 5-30=±0.4 315-1000=±1.6
 30-120±0.6 1000-2000=±2.4

SCALE 4:1 SIZE A

REVISION

DESCRIPTION ENGINEER