

NO	DESCRIPTION	MATERIAL	Q'TY	FINISH	REMARK
1	BODY 1	BRASS	1	NICKEL	B-SMA0065-N
2	INSULATION 1	TEFLON	1	TEFLON	I-0160T
3	BODY2	BRASS	1	NICKEL	B-BNC0361-N
4	WASHER	BRASS	1	BRASS	W-0025-N
5	SPRING	BRASS	1	NICKEL	W-0024-N
6	WASHER	BRASS	1	NICKEL	W-0026-N
7	GASKET	SI RUBBER	1	RUBBER	RU-0010
8	BODY 3	BRASS	1	NICKEL	B-TNC0083-N
9	INSULATION 2	TEFLON	1	TEFLON	I-0172T
10	PIN	PH.BRONZE	1	GOLD	P-SMA0274-G

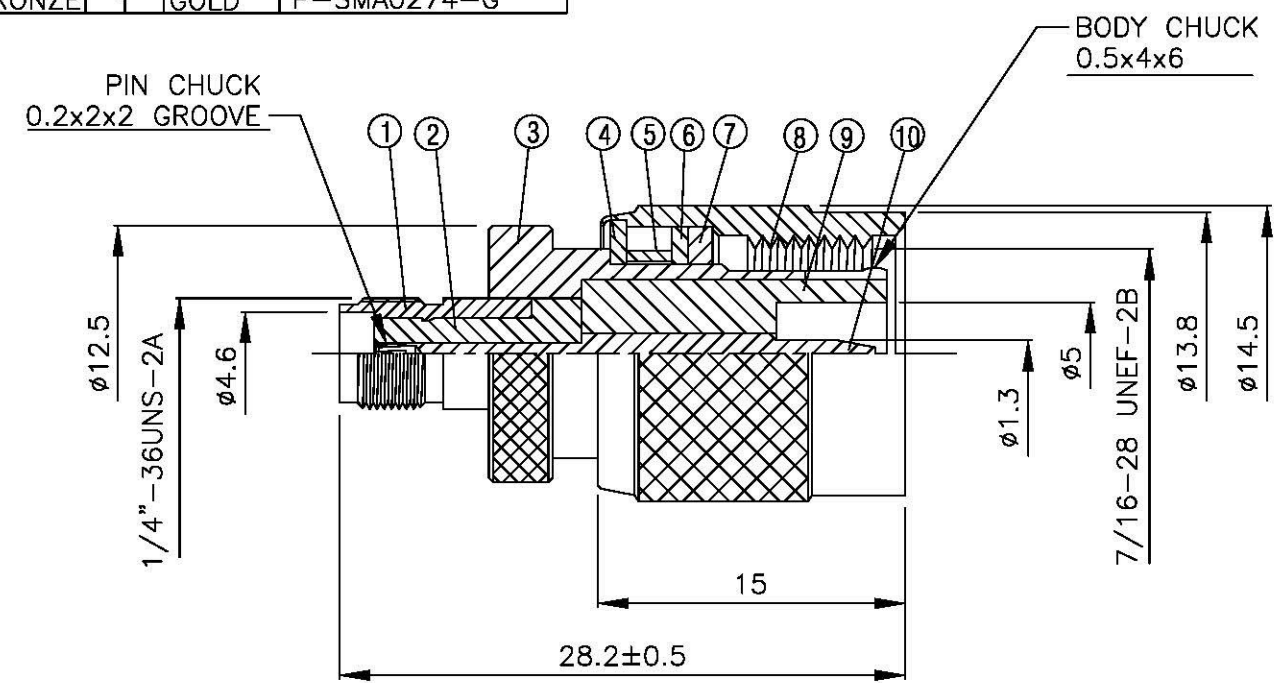
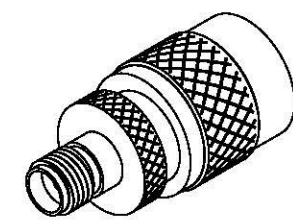
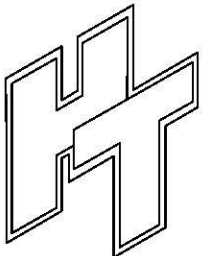

	All Connectors <small>www.allconnectors.de info@allconnectors.de Tel: 0049 714 709204 70794 Gilderstadt - Germany</small>	DRAWN MARY DATE 96.03.27	DIMENSIONS ARE IN MILLIMETERS		REVISION	
		CHECKED 蘇志欣 DATE 97.04.29	UNLESS OTHERWISE SPECIFIED TOLERANCE		DESCRIPTION	ENGINEER
		Q.A. 蘇姿潔 DATE	$0.5-5 = \pm 0.2$	$120-315 = \pm 1$		
		APPROVAL 徐燦霖 DATE	$5-30 = \pm 0.4$	$315-1000 = \pm 1.6$		
		REVISION	$30-120 = \pm 0.6$	$1000-2000 = \pm 2.4$		
TITLE SMA FEMALE-TNC MALE ADAPTOR	PART NO. SMA-27-TGN	DRAWING NO. SMA 27 TGN	SCALE 4:1	SIZE A		