

NO	DESCRIPTION	MATERIAL	Q'TY	FINISH	REMARK
1	SHELL	BRASS	1	NICKEL	B-SMA0043-N
2	GASKET	RUBBER	1	RUBBER	RU-0008
3	WASHER	BRASS	1	NICKEL	W-0012-N
4	INSULATION	TEFLON	1	TEFLON	I-0138T
5	BODY 1	BRASS	1	NICKEL	B-SMA0154-N
6	BODY 2	BRASS	1	NICKEL	B-TNC0423-N
7	PIN	BRASS	1	GOLD	P-SMA0257-G
8	INSULATION	TEFLON	1	TEFLON	I-0189T
9	WASHER	BRASS	1	NICKEL	W-0007-N

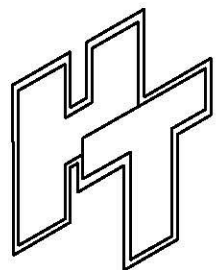
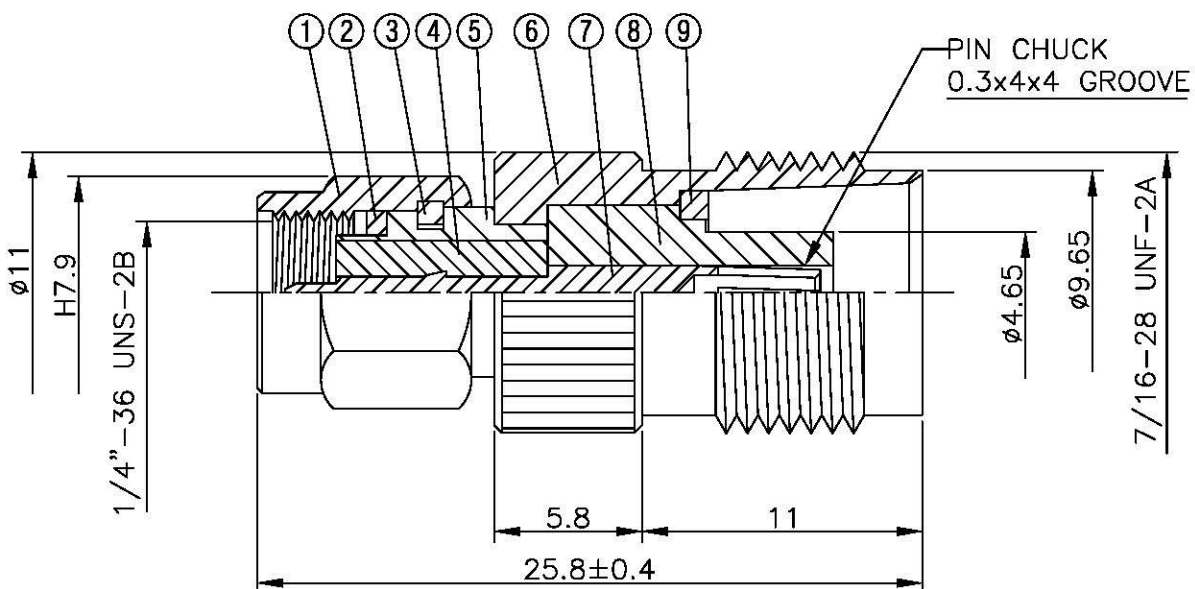
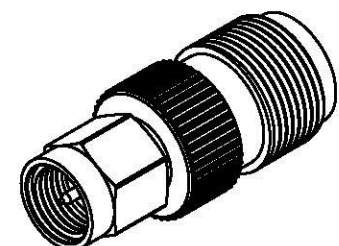

All Connectors
 www.allconnectors.de info@allconnectors.de
 Tel.: 0049 711 200950 Fax: 0049 711 200954
 20796 Hildersdorf, Germany Kollmannstr. 25

TITLE
SMA MALE - TNC FEMALE ADAPTOR

PART NO. SMA-22-TGN

DRAWING NO. SMA 22 TGN

DRAWN	MARY	DATE	96.03.28
CHECKED	黃巧君	DATE	
Q.A.	蘇姿潔	DATE	
APPROVAL	徐燦霖	DATE	
REVISION		DATE	

DIMENSIONS ARE IN MILLIMETERS			
UNLESS OTHERWISE SPECIFIED TOLERANCE			
0.5-5=±0.2	120-315=±1		
5-30=±0.4	315-1000=±1.6		
30-120=±0.6	1000-2000=±2.4		
SCALE	4:1	SIZE	A

REVISION	
DESCRIPTION	ENGINEER