

NO	DESCRIPTION	MATERIAL	Q'TY	FINISH	REMARK
1	SHELL	BRASS	1	NICKEL	B-SMA0043-N
2	GASKET	RUBBER	1	RUBBER	RU-0008
3	WASHER	BRASS	1	NICKEL	W-0012
4	INSULATION	TEFLON	1	TEFLON	I-0126T
5	BODY 1	BRASS	1	NICKEL	B-SMA0154-N
6	BODY 2	BRASS	1	NICKEL	B-BNC0401-N
7	PIN	BRASS	1	GOLD	P-SMA0257-G
8	INSULATION	TEFLON	1	TEFLON	I-0189T
9	WASHER	BRASS	1	NICKEL	W-0007-N

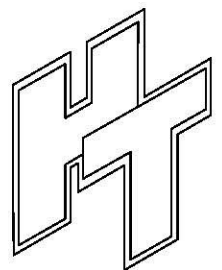
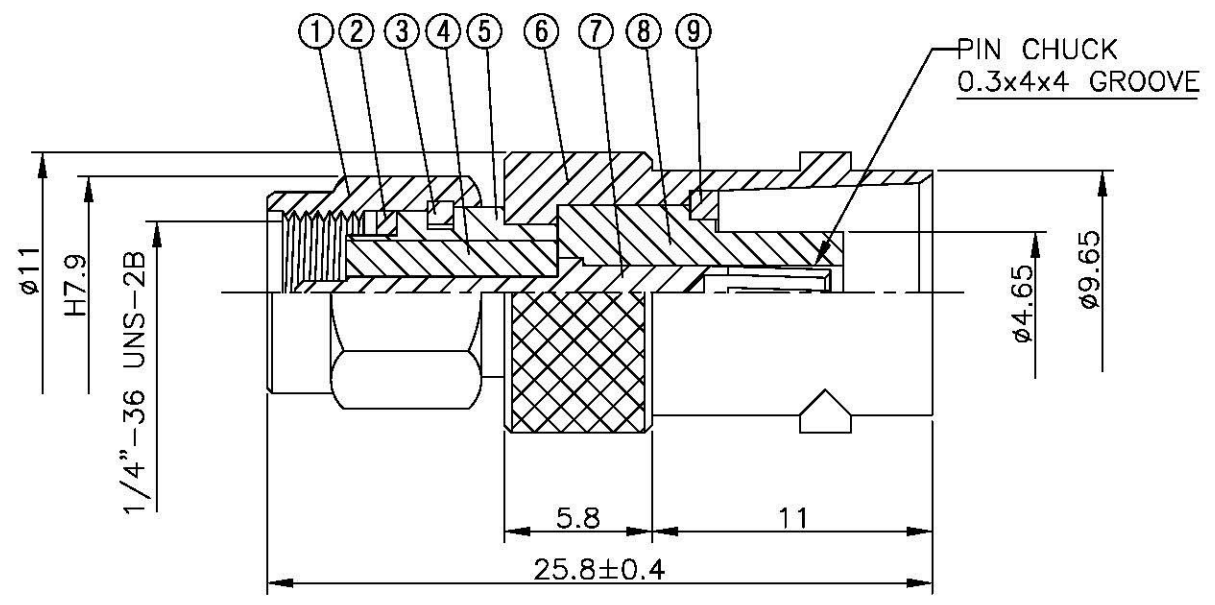
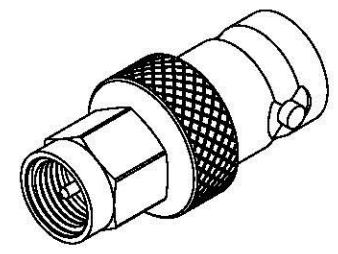

All Connectors
 www.allconnectors.de
 Tel: 0049 711 7005800
 70734 Hildersstadt, Germany

info@allconnectors.de
 Fax: 0049 711 7005801
 Kottbusstr. 25

TITLE
SMA MALE - BNC FEMALE ADAPTOR

PART NO. **SMA-20-TGN**

DRAWING NO. **SMA 20 TGN**

DRAWN **MARY** DATE **96.03.29**

CHECKED **蘇姿潔** DATE

Q.A. **馮健華** DATE

APPROVAL **徐燦霖** DATE

REVISION DATE

DIMENSIONS ARE IN MILLIMETERS

UNLESS OTHERWISE SPECIFIED TOLERANCE

0.5-5=±0.2 120-315=±1
 5-30=±0.4 315-1000=±1.6
 30-120=±0.6 1000-2000=±2.4

SCALE **4:1** SIZE **A**

REVISION	
DESCRIPTION	ENGINEER