

NO	DESCRIPTION	MATERIAL	Q'TY	FINISH	REMARK
1	SHELL	BRASS	1	NICKEL	B-SMA0043-N
2	INSULATION	TEFLON	1	TEFLON	I-0126T
3	GASKET	SI RUBBER	1	RUBBER	RU-0008
4	WASHER	PH. BRONZE	1	GOLD	W-0012
5	BODY1	BRASS	1	NICKEL	B-SMA0154-N
6	BODY2	BRASS	1	NICKEL	B-BNC0361-N
7	WASHER	BRASS	1	BRASS	W-0025-N
8	SPRING	SK-5	1	NICKEL	W-0027-N
9	WASHER	BRASS	1	NICKEL	W-0026-N
10	GASKET	SI RUBBER	1	RUBBER	RU-0010
11	BODY3	BRASS	1	NICKEL	B-BNC0184-N
12	INSULATION	TEFLON	1	TEFLON	I-0172T
13	PIN	BRASS	1	GOLD	P-SMA0233-G

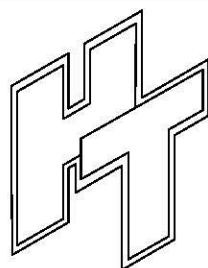
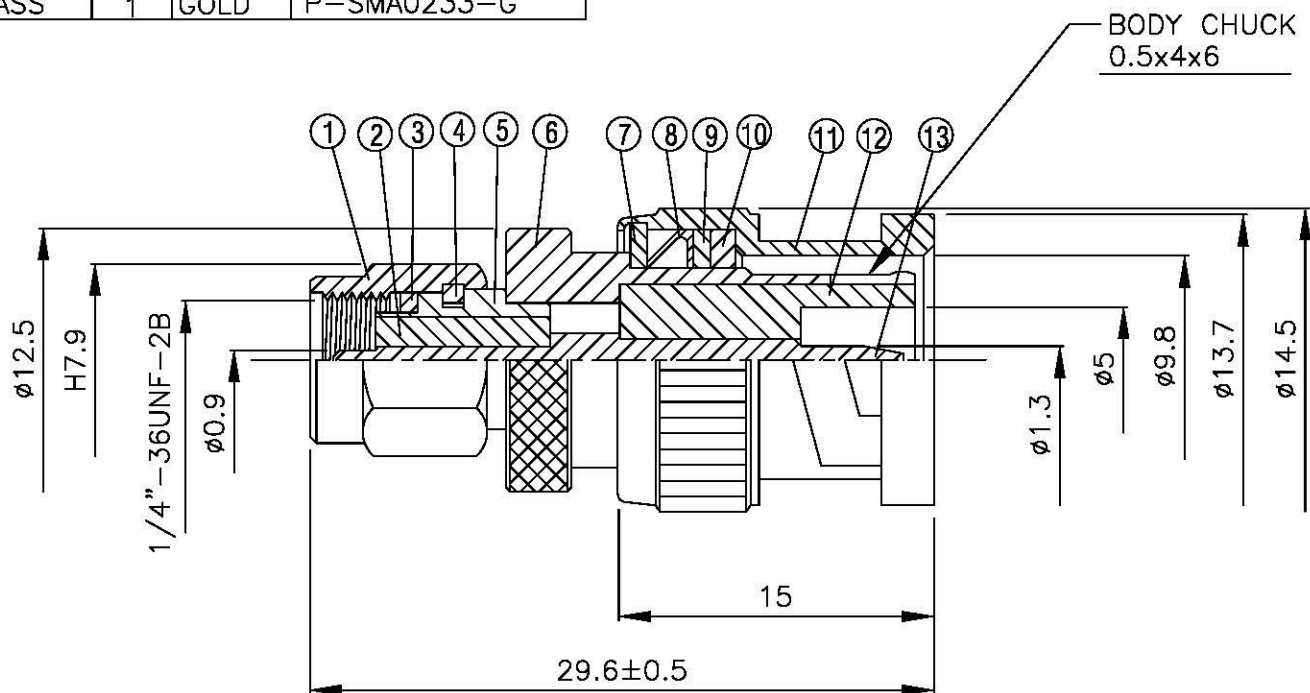
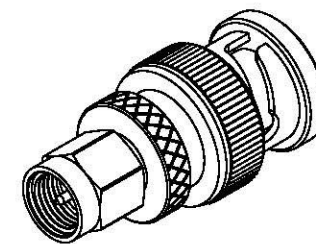

**All Connectors**

www.allconnectors.de info@allconnectors.de  
Tel: 0049 711 7095532 Fax: 0049 711 7095501  
Mittelstraße 16 Germany Kettelerstr. 22

TITLE  
**SMA MALE-BNC MALE ADAPTOR**

PART NO.  
**SMA-19-TGN**

DRAWING NO.  
**SMA 19 TGN**

DRAWN **MARY** DATE **96.03.28**

CHECKED **蘇姿潔** DATE

Q.A. **馮健華** DATE

APPROVA **徐燦霖** DATE

REVISION DATE

DIMENSIONS ARE IN MILLIMETERS

UNLESS OTHERWISE SPECIFIED TOLERANCE

0.5-5=±0.2	120-315=±1
5-30=±0.4	315-1000=±1.6
30-120±0.6	1000-2000=±2.4

SCALE 4:1 SIZE A

REVISION

DESCRIPTION	ENGINEER