

NO	DESCRIPTION	MATERIAL	Q'TY	FINISH	REMARK
1	BODY 1	BRASS	1	NICKEL	B-SMA0043-N
2	BODY 2	BRASS	1	NICKEL	B-SMA0154-N
3	RUBBER 1	SI RUBBER	1	RUBBER	RU-0008
4	WASHER	PH.BRONZE	1	NICKEL	W-0012
5	INSULATION	TEFLON	1	TEFLON	I-0306T
6	BODY 4	BRASS	1	NICKEL	B-N0651-N
7	INSULATION	TEFLON	1	TEFLON	I-0283T
8	WASHER	BRASS	1	NICKEL	W-0014
9	RUBBER 2	SI RUBBER	1	RUBBER	RU-0007
10	PIN	BRASS	1	GOLD	P-SMA0429-G
11	BODY 5	BRASS	1	NICKEL	B-N0032-N
12	BODY 6	BRASS	1	NICKEL	B-N0033-N

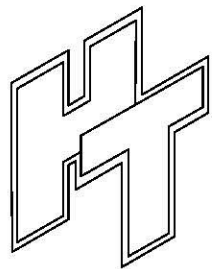
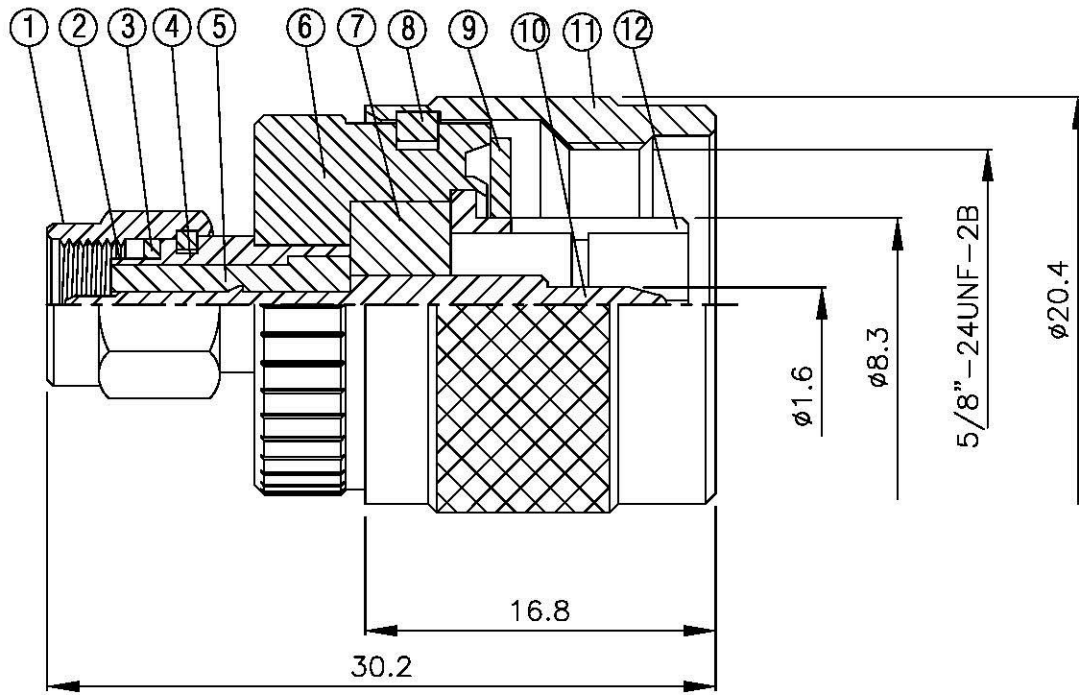
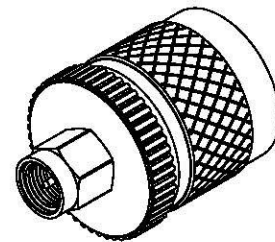

All Connectors
 www.allconnectors.de info@allconnectors.de
 41-218070 211 4181013 41-218070 211 4181013
 70754 Allendorf - Germany Kettelerstr. 25

TITLE SMA MALE N MALE ADAPTOR

PART NO. SMA-17-TGN

DRAWING NO. SMA 17 TGN

DRAWN	MARY	DATE	96.03.29
CHECKED	蘇姿潔	DATE	
Q.A.	馮健華	DATE	
APPROVA	徐燦霖	DATE	
REVISION		DATE	

DIMENSIONS ARE IN MILLIMETERS			
UNLESS OTHERWISE SPECIFIED TOLERANCE			
0.5-5=±0.2	120-315=±1		
5-30=±0.4	315-1000=±1.6		
30-120±0.6	1000-2000=±2.4		
SCALE	4:1	SIZE	A

REVISION	
DESCRIPTION	ENGINEER