

NO	DESCRIPTION	MATERIAL	Q'TY	FINISH	REMARK
1	BODY 1	BRASS	1	NICKEL	B-SMA0971-G
2	INSULATION 1	TEFLON	1	TEFLON	I-0131T
3	BODY 2	BRASS	1	NICKEL	B-SMA0972-G
4	PIN	BRASS	1	GOLD	P-SMA0635-G
5	BODY 3	BRASS	1	GOLD	B-SMA0396-G
6	INSULATION 2	TEFLON	1	TEFLON	I-0470T

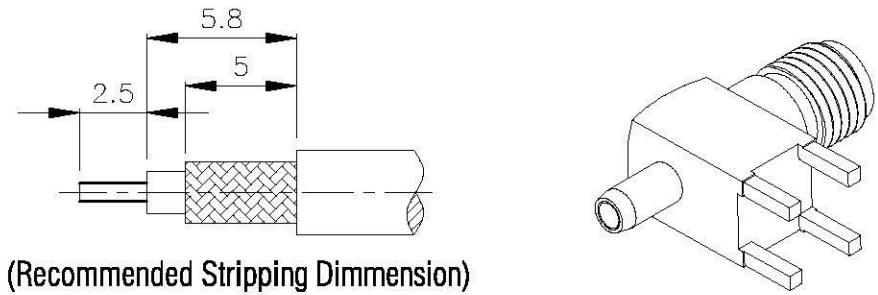

(Recommended Stripping Dimension)

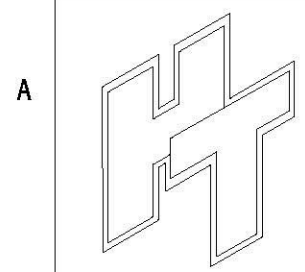
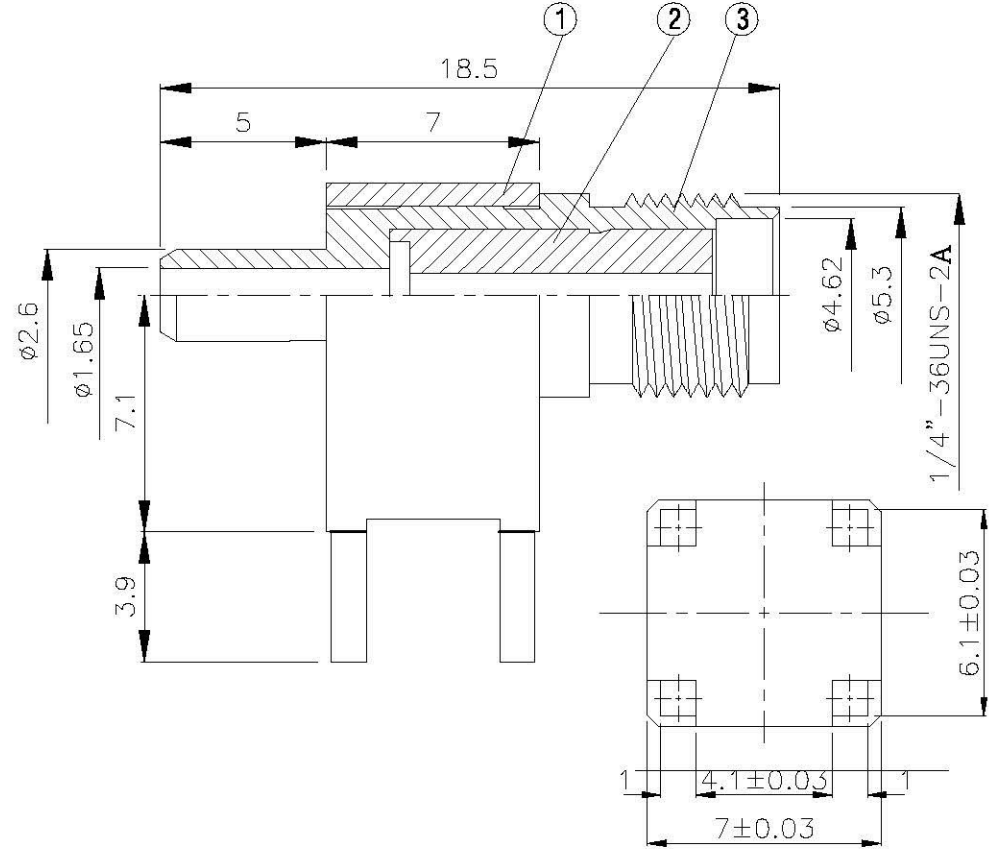
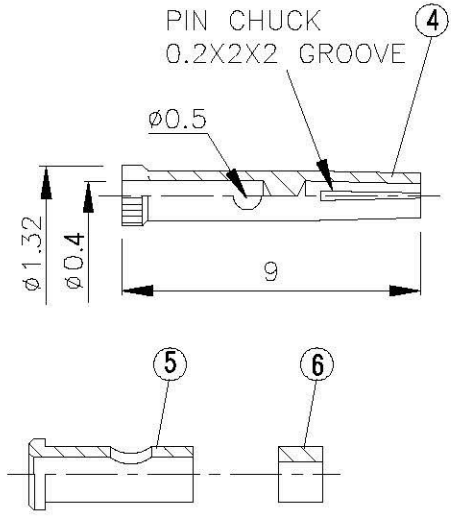

All Connectors
 www.allconnectors.de
 Tel.: 0049 711 7005503
 70794 Filderstadt (Germany)

Info@allconnectors.de
 Fax: 0049 711 7005504
 Kottbusstr. 25

TITLE SMA FEMALE CRIMP FOR C-1.37mm CABLE

PART NO. SMA-11U3-TGG

DRAWING NO. SMA-11U3-TGG

DRAWN 蘇姿潔 **DATE** 97.07.07

CHECKED 蘇志欣 **DATE**

Q.A. 莊千慧 **DATE**

APPROVAL 徐燦霖 **DATE**

REVISION **DATE**

DIMENSIONS ARE IN MILLIMETERS

UNLESS OTHERWISE SPECIFIED TOLERANCE

0.5-5=±0.2 120-315=±1
 5-30=±0.4 315-1000=±1.6
 30-120±0.6 1000-2000=±2.4

SCALE 4:1 **SIZE A**

REVISION	
DESCRIPTION	ENGINEER