

NO	DESCRIPTION	MATERIAL	Q'TY	FINISH	REMARK
1	BODY 1	BRASS	1	NICKEL	B-SMA0971-G
2	INSULATION 1	TEFLON	1	TEFLON	I-0131T
3	BODY 2	BRASS	1	NICKEL	B-SMA0972-G
4	PIN	BE CU	1	GOLD	P-SMA0635-G
5	BODY 3	BRASS	1	GOLD	B-SMA0473-G
6	INSULATION 2	TEFLON	1	TEFLON	I-0470T

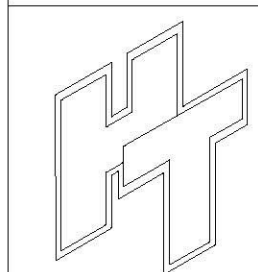
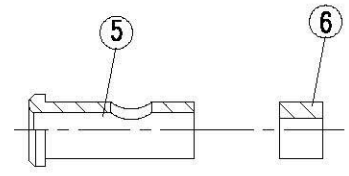
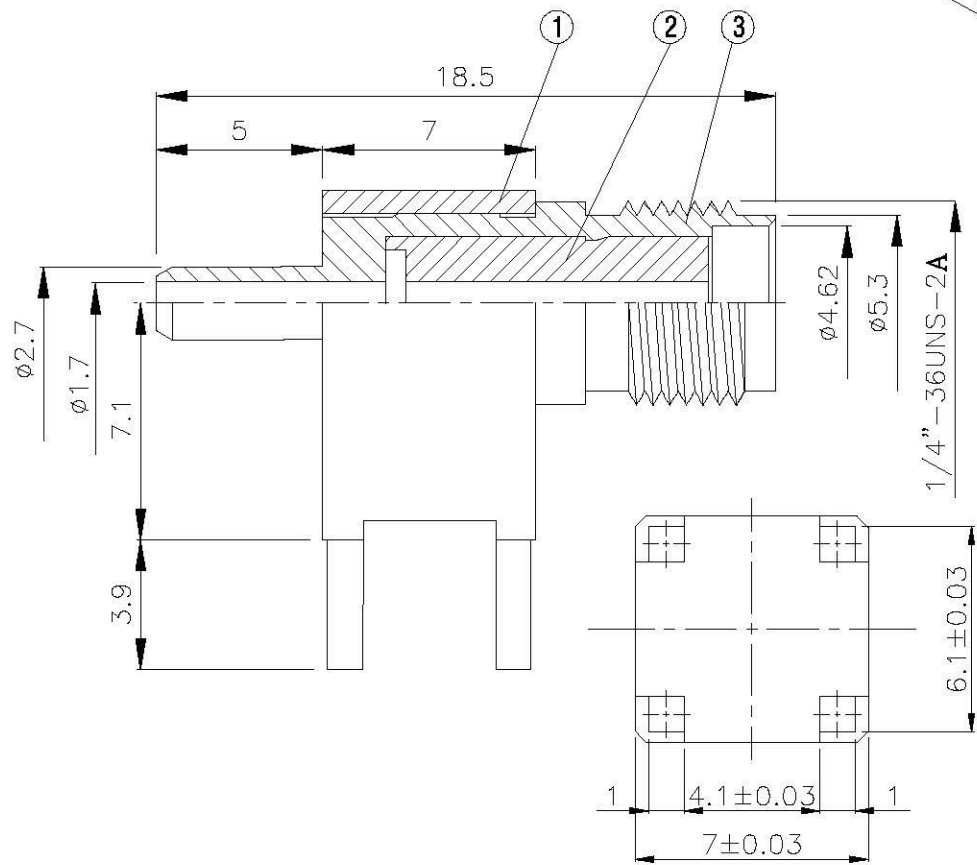
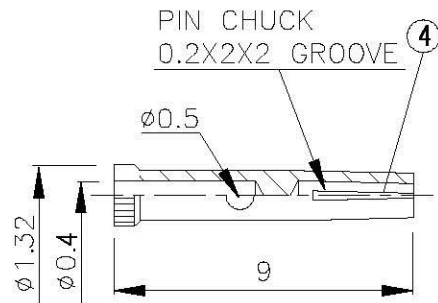
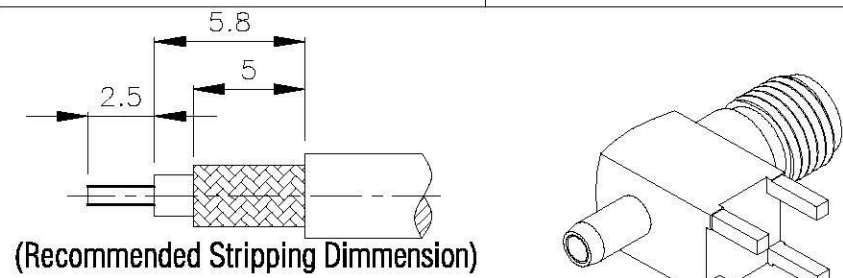

All Connectors
 www.allconnectors.de
 Tel.: 0049 711 2006503
 20794 Finkenheerd - Germany
 info@allconnectors.de
 Fax: 0049 711 2006504
 Kitemark reg. 25

TITLE SMA FEMALE CRIMP FOR RG-178/U
PART NO. SMA-11M-TGG
DRAWING NO. SMA-11M-TGG

DRAWN MARY
CHECKED 蘇姿潔
Q.A. 馮健華
APPROVAL 徐燦霖
REVISION

DATE 96.03.16
DATE
DATE
DATE

DIMENSIONS ARE IN MILLIMETERS

UNLESS OTHERWISE SPECIFIED TOLERANCE

0.5-5=±0.2	120-315=±1
5-30=±0.4	315-1000=±1.6
30-120±0.6	1000-2000=±2.4

SCALE 4:1 **SIZE** A

REVISION	
DESCRIPTION	ENGINEER