

NO	DESCRIPTION	MATERIAL	Q'TY	FINISH	REMARK
1	BODY 1	BRASS	1	NICKEL	B-SMA0971-G
2	INSULATION	TEFLON	1	TEFLON	I-0131T
3	BODY 2	BRASS	1	NICKEL	B-SMA0970-G
4	PIN	BE CU	1	GOLD	P-SMA0056-G
5	RING	BRASS	1	NICKEL	R-0001

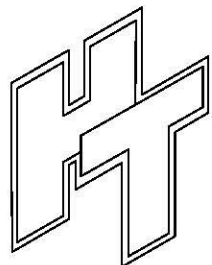
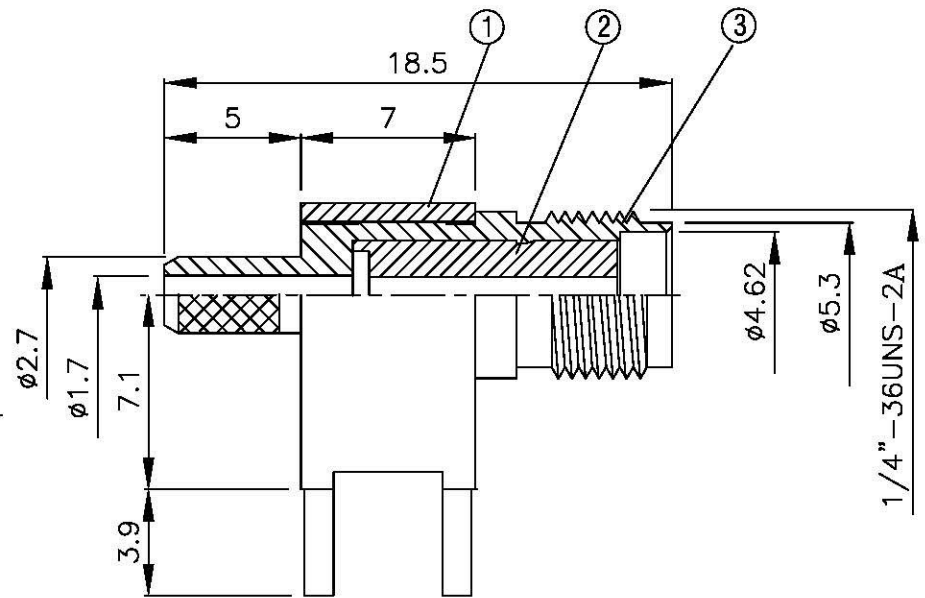
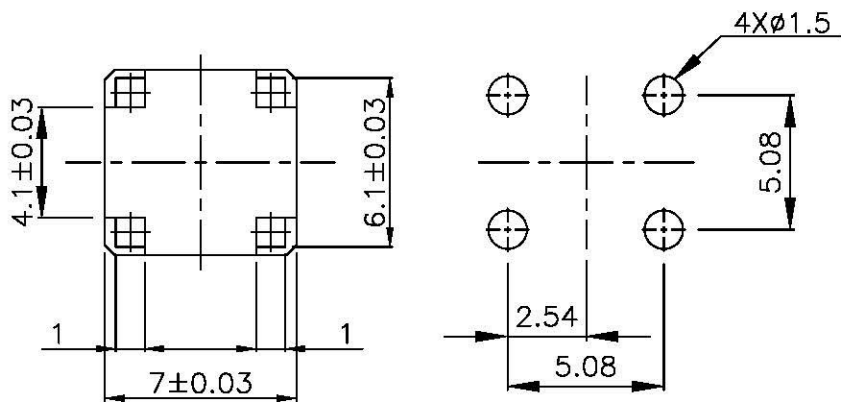
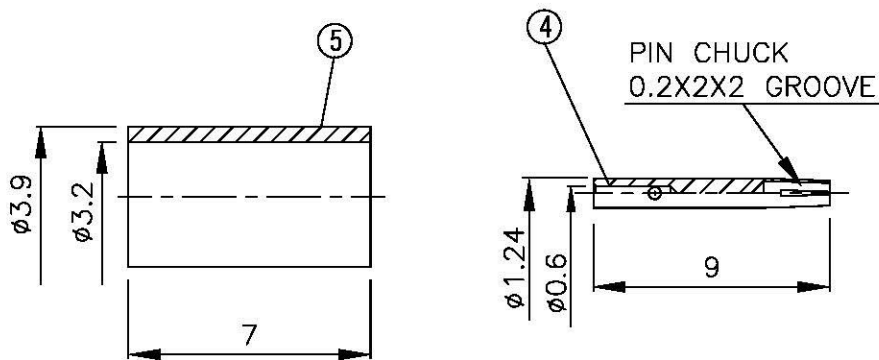
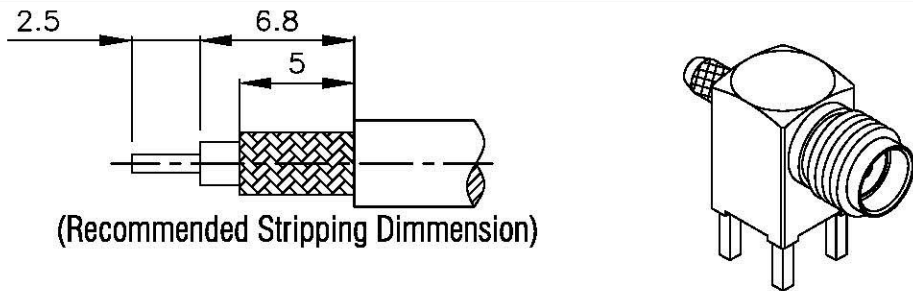

**All Connectors**  
 www.allconnectors.com    info@allconnectors.com  
 TEL: 0049 711 2003303    Fax: 0049 711 2003304  
 20724 FRIEDRICH - Germany    R&D: 0049 711 2003302

TITLE **SMA FEMALE CRIMP FOR RG-174/U, RG-316/U**  
 PART NO. **SMA-11LV1-TGG**  
 DRAWING NO. **SMA-11LV1-TGG**

DRAWN **MARY**    DATE **96.03.15**  
 CHECKED **蘇姿潔**    DATE  
 Q.A. **馮健華**    DATE  
 APPROVAL **徐燦霖**    DATE  
 REVISION    DATE

DIMENSIONS ARE IN MILLIMETERS  
 UNLESS OTHERWISE SPECIFIED TOLERANCE  
 0.5-5=±0.2    120-315=±1  
 5-30=±0.4    315-1000=±1.6  
 30-120±0.6    1000-2000=±2.4  
 SCALE **4:1**    SIZE **A**

REVISION	
DESCRIPTION	ENGINEER