

NO	DESCRIPTION	MATERIAL	Q'TY	FINISH	REMARK
1	BODY	BRASS	1	GOLD	B-SMA0336-G
2	PIN	BE CU	1	GOLD	P-SMA0205-G
3	INSULATION	TEFLON	1	TEFLON	I-0162T

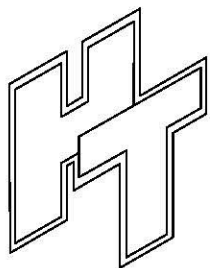
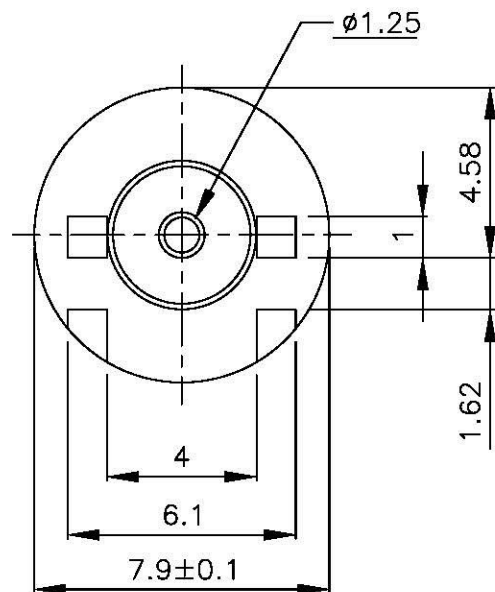
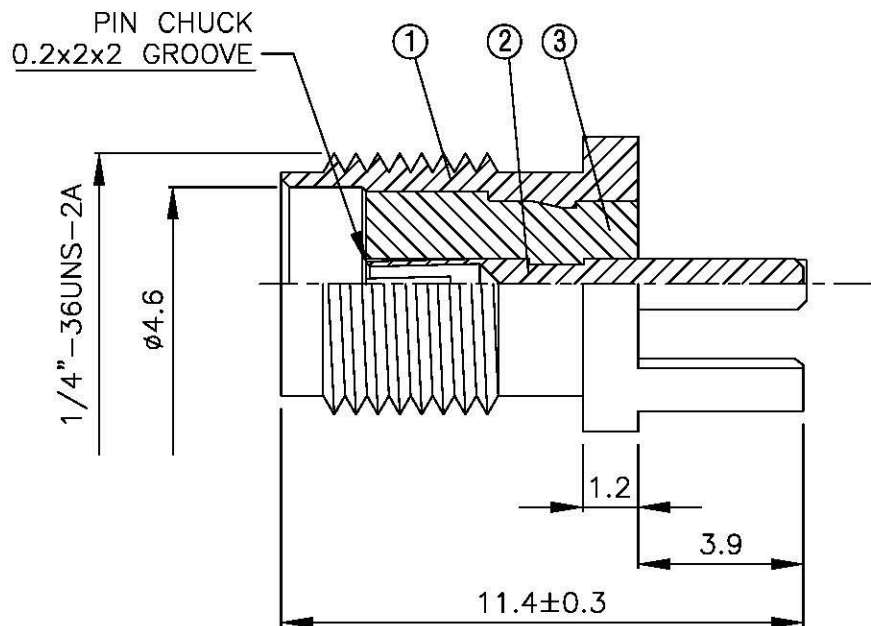
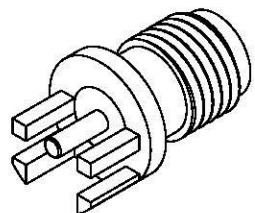

All Connectors

www.allconnectors.com
 11002244 1111 11002244
 11002244 1111 11002244

DRAWN	MARY	DATE	90.11.20
CHECKED	蘇姿潔	DATE	90.11.20
Q.A.	馮健華	DATE	
APPROVAL	徐燦霖	DATE	
REVISION		DATE	

TITLE SMA FEMALE END LAUNCH

PART NO. SMA-10V17-TGG

DRAWING NO. SMA 10V17 TGG

DIMENSIONS ARE IN MILLIMETERS

UNLESS OTHERWISE SPECIFIED TOLERANCE

0.5-5=±0.2	120-315=±1
5-30=±0.4	315-1000=±1.6
30-120±0.6	1000-2000=±2.4

SCALE 4:1 SIZE A

REVISION

DESCRIPTION ENGINEER
