

NO	DESCRIPTION	MATERIAL	Q'TY	FINISH	REMARK
1	BODY	BRASS	1	GOLD	B-SMA0376-G
2	INSULATION	TEFLON	1	TEFLON	I-0016T
3	PIN	BE CU	1	GOLD	P-SMA0098-G
4	NUT	BRASS	1	GOLD	N-0006-G
5	WASHER	BRASS	1	GOLD	W-0016-G

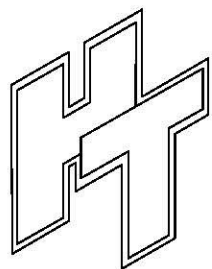
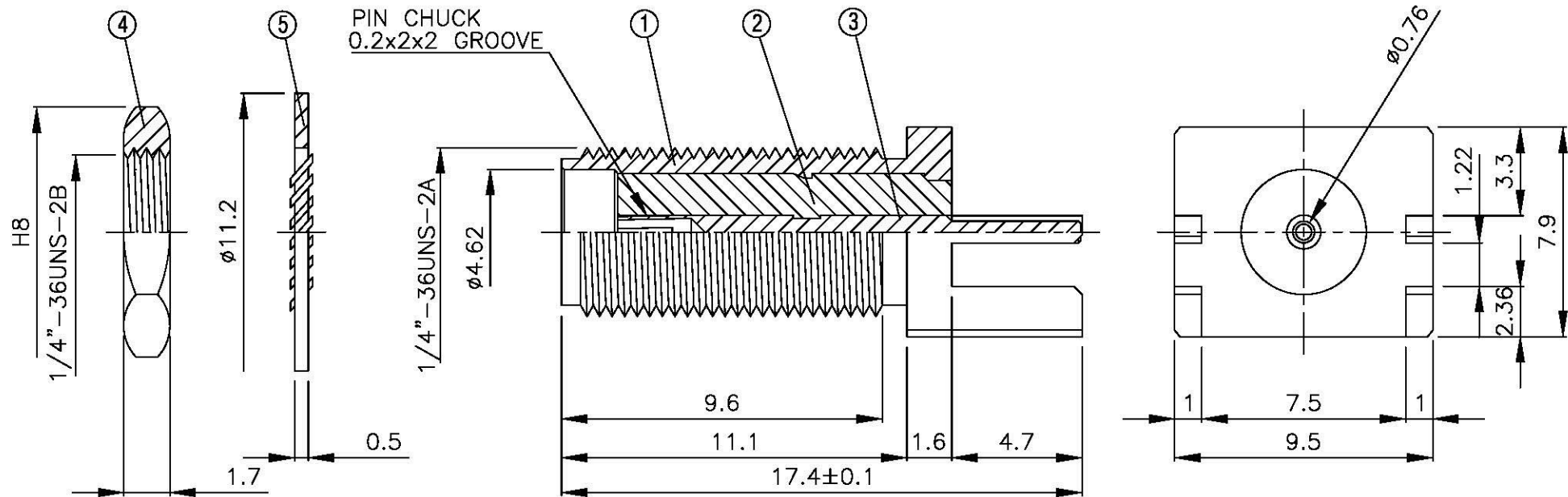
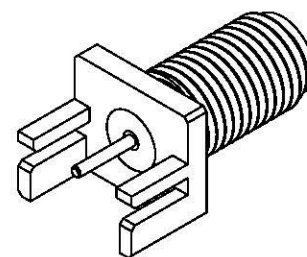

All Connectors

www.allconnectors.com
Tel: 0049 (0) 711 7008900
Fax: 0049 (0) 711 7008904

TITLE SMA FEMALE END LAUNCH
TAB CONTACT (BOARD THICKNESS 1.07)

PART NO. SMA-10V12-TGG

DRAWING NO. SMA 10V12 TGG

DRAWN	MARY	DATE	96.03.27
CHECKED	蘇姿潔	DATE	
Q.A.	馮健華	DATE	
APPROVAL	徐燦霖	DATE	
REVISION		DATE	

DIMENSIONS ARE IN MILLIMETERS			
UNLESS OTHERWISE SPECIFIED TOLERANCE			
0.5-5=±0.2	120-315=±1		
5-30=±0.4	315-1000=±1.6		
30-120±0.6	1000-2000=±2.4		
SCALE	4:1	SIZE	A

REVISION	
DESCRIPTION	ENGINEER