

NO	DESCRIPTION	MATERIAL	Q'TY	FINISH	REMARK
1	BODY	BRASS	1	GOLE	B-SMA0078-G
2	INSULATION	TEFLON	1	TEFLON	I-0115T
3	PIN	BE CU	1	GOLD	P-SMA0761-G

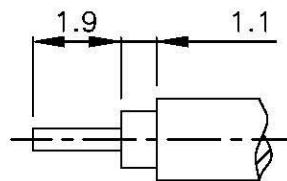

(Recommended Stripping Dimension)

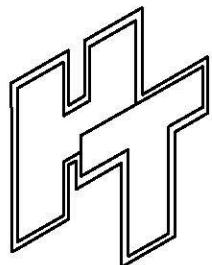
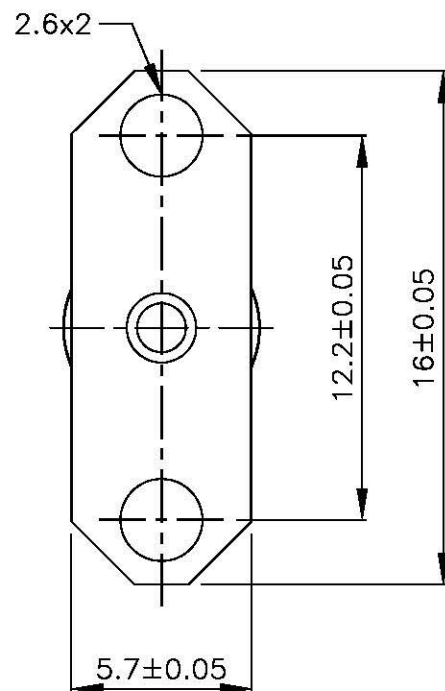
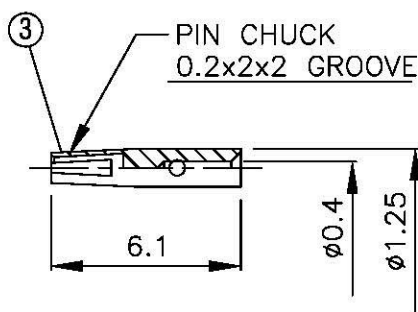
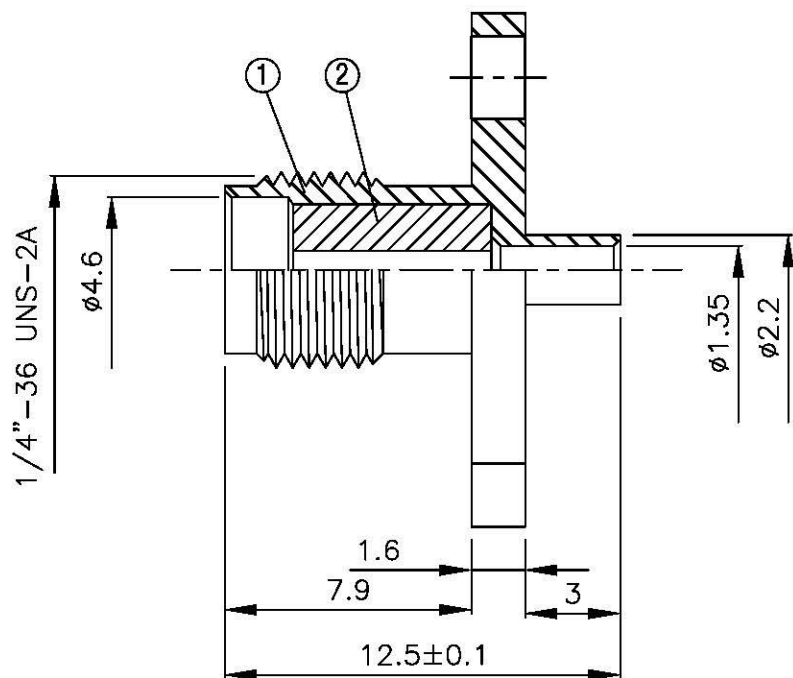
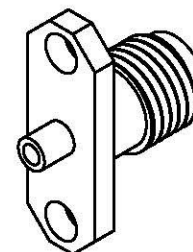

All Connectors
 www.allconnectors.de
 Tel: +0049 711 7065903
 70764 Rietzstadt, Germany
 info@allconnectors.de
 Fax: +0049 711 7065904
 Kofu@allconnectors.de

TITLE SMA FEMALE PANEL SOLDER FOR M17/151 (.047)
 PART NO. SMA-08V3-TGG
 DRAWING NO. SMA-08V3-TGG

DRAWN	MARY	DATE	96.03.29
CHECKED	蘇姿潔	DATE	
Q.A.	馮健華	DATE	
APPROVAL	徐燦霖	DATE	
REVISION		DATE	

DIMENSIONS ARE IN MILLIMETERS			
UNLESS OTHERWISE SPECIFIED TOLERANCE			
0.5-5=±0.2	120-315=±1		
5-30=±0.4	315-1000=±1.6		
30-120±0.6	1000-2000=±2.4		
SCALE	4:1	SIZE	A

REVISION	
DESCRIPTION	ENGINEER