

NO	DESCRIPTION	MATERIAL	Q'TY	FINISH	REMAEK
1	BODY	BRASS	1	NICKEL	B-SMA0070-N
2	INSULATION	TEFLON	1	TEFLON	I-0115T
3	PIN	BE CU	1	GOLD	P-SMA0049-G
4	RING	BRASS	1	GOLD	R-0002-G

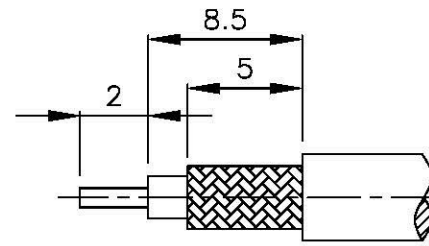

(Recommended Stripping Dimension)

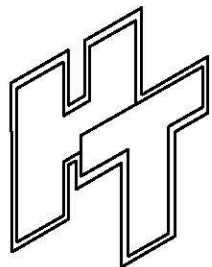
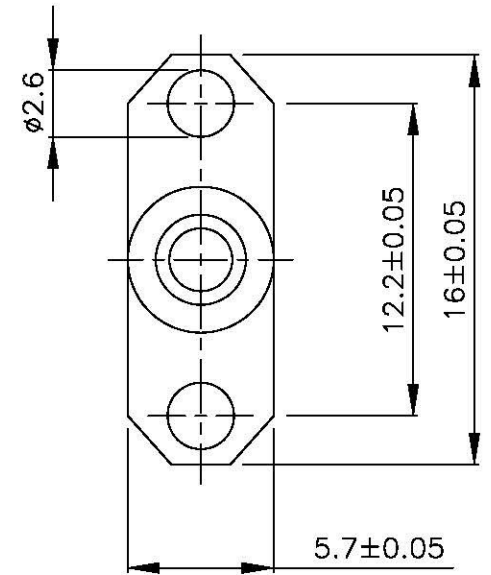
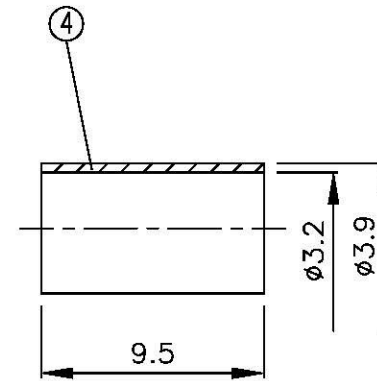
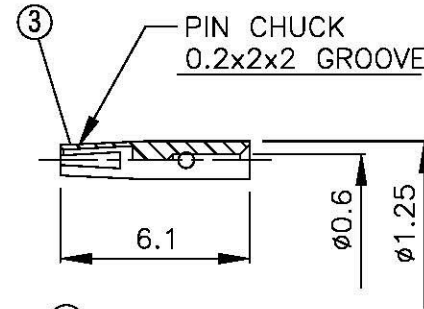
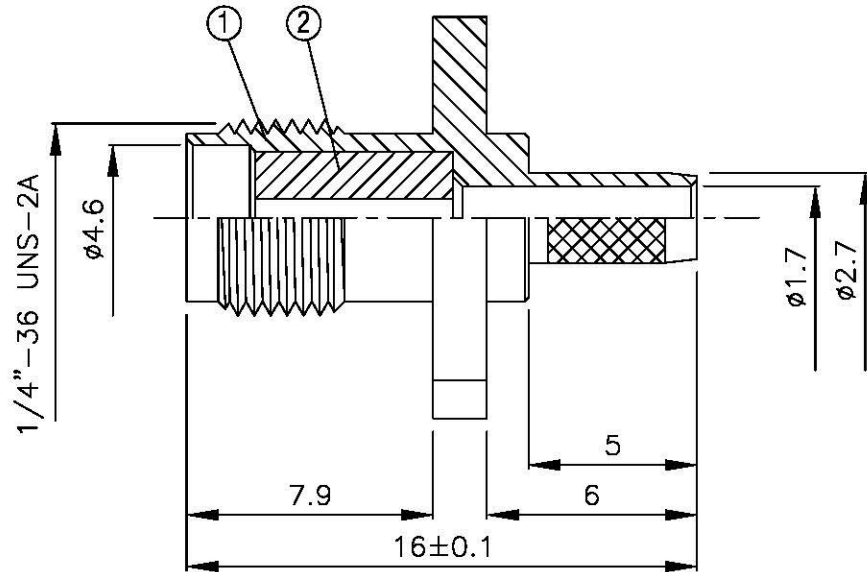
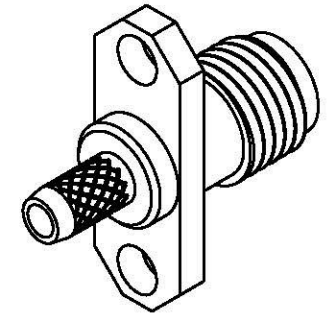

**All Connectors**

www.allconnectors.de info@allconnectors.de  
 Tel: 0049 711 7005503 Fax: 0049 711 7005504  
 41764 Kilsbacht Germany Kalsbecherstr. 22

TITLE SMA FEMALE PANEL CRIMP FOR RG-174/U

PART NO. SMA-08LV1-TGN

DRAWING NO. SMA 08LV1 TGN

DRAWN MARY DATE 96.03.15

CHECKED 黄巧君 DATE

Q.A. 蘇姿潔 DATE

APPROVAL 徐燦霖 DATE

REVISION DATE

DIMENSIONS ARE IN MILLIMETERS

UNLESS OTHERWISE SPECIFIED TOLERANCE

0.5-5=±0.2	120-315=±1
5-30=±0.4	315-1000=±1.6
30-120±0.6	1000-2000=±2.4

SCALE 4:1 SIZE A

REVISION

DESCRIPTION	ENGINEER