

NO	DESCRIPTION	MATERIAL	Q'TY	FINISH	REMAEK
1	BODY	BRASS	1	NICKEL	B-SMA0536-N
2	INSULATION	TEFLON	1	TEFLON	I-0115T
3	PIN	BE CU	1	GOLD	P-SMA0120-G
4	INSULATION	TEFLON	1	TEFLON	I-0256T
5	BODY	BRASS	1	NICKEL	B-SMA0473-N

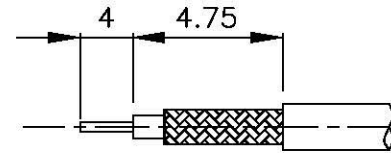

(Recommended Stripping Dimension)

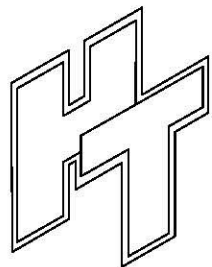
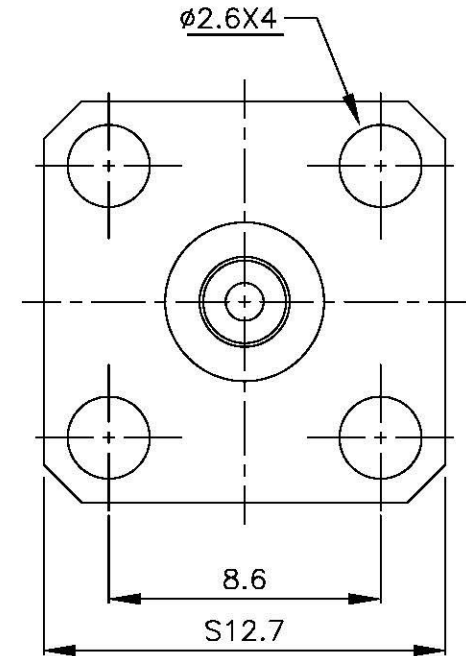
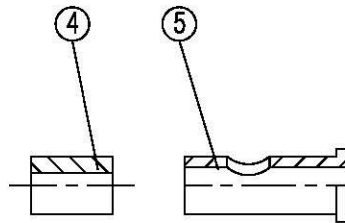
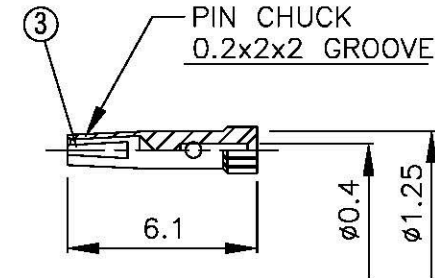
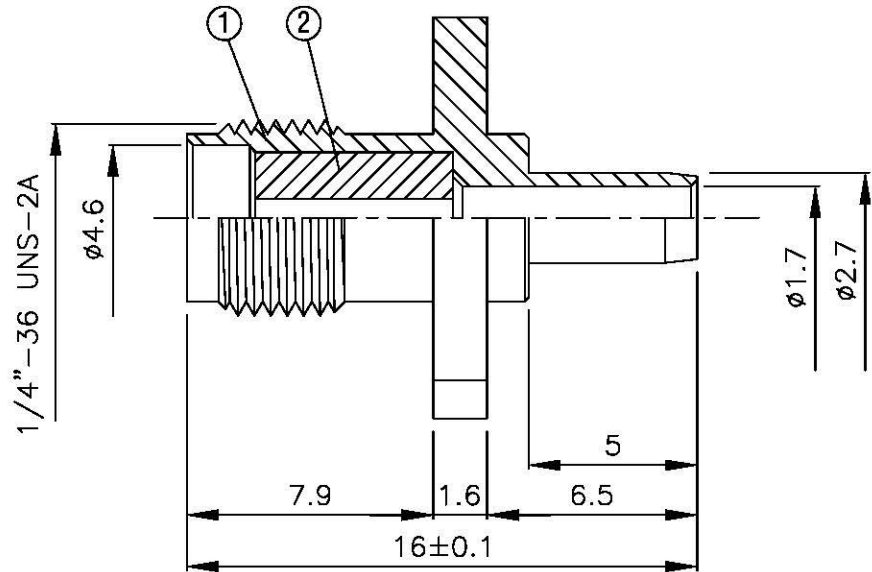
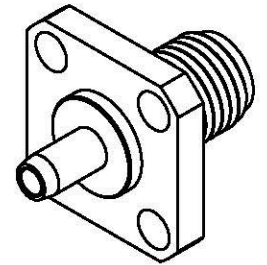

**All Connectors**  
 www.allconnectors.de  
 Tel: 0049 711 7091900  
 70293 Ellwangen - Germany

Info@allconnectors.de  
 Fax: 0049 711 7091904  
 kramm@allconnectors.de

TITLE SMA FEMALE PANEL CRIMP FOR RG-178/U

PART NO. SMA-07M-TGN

DRAWING NO. SMA 07M TGN

DRAWN MARY DATE 96.03.15

CHECKED 黄巧君 DATE

Q.A. 蘇姿潔 DATE

APPROVAL 徐燦霖 DATE

REVISION DATE

DIMENSIONS ARE IN MILLIMETERS

UNLESS OTHERWISE SPECIFIED TOLERANCE

0.5-5=±0.2	120-315=±1
5-30=±0.4	315-1000=±1.6
30-120±0.6	1000-2000=±2.4

SCALE 4:1 SIZE A

REVISION

DESCRIPTION	ENGINEER