

NO	DESCRIPTION	MATERIAL	Q'TY	FINISH	REMAEK
1	BODY	BRASS	1	NICKEL	B-SMA0067-N
2	INSULATION	TEFLON	1	TEFLON	I-0115T
3	PIN	BE CU	1	GOLD	P-SMA0049-G
4	RING	BRASS	1	NICKEL	R-0002-N

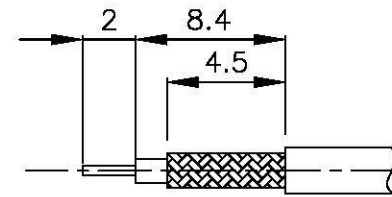

(Recommended Stripping Dimension)

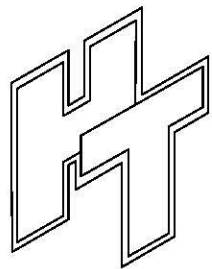
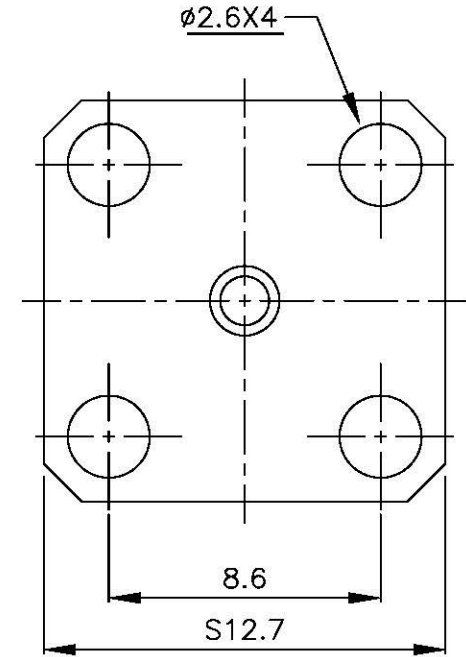
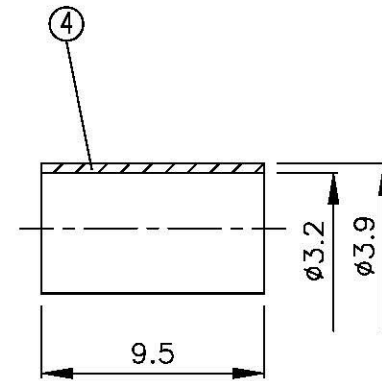
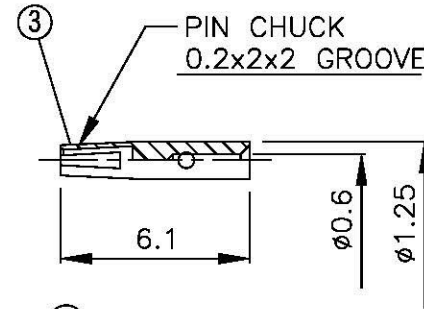
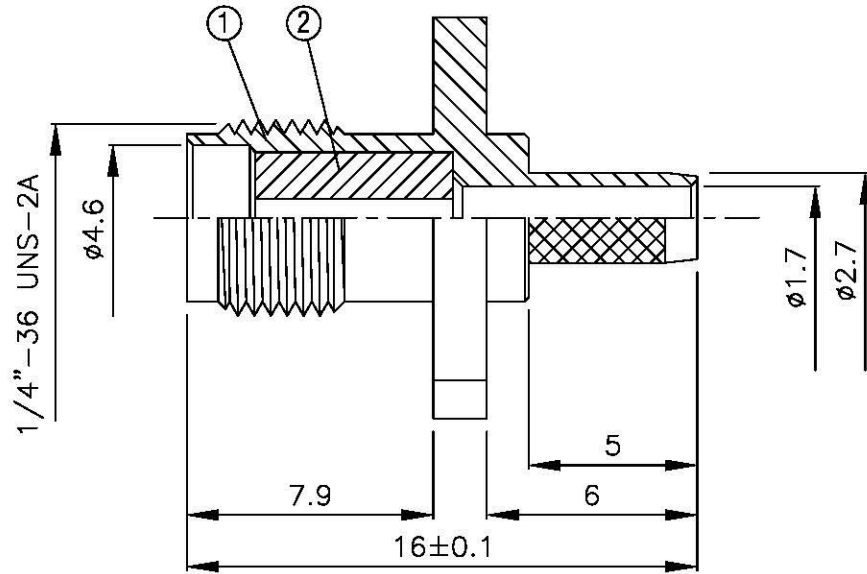
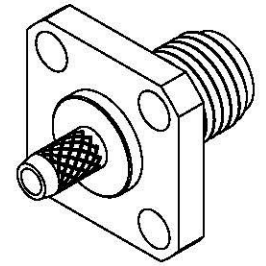

**All Connectors**  
 www.allconnectors.com  
 4400 Old Orchard Road, Suite 200  
 Allentown, PA 18106-1000, USA  
 Tel: 610-261-2222 Fax: 610-261-2223

TITLE SMA FEMALE PANEL CRIMP FOR RG-174/U

PART NO. SMA-07LV1-TGN

DRAWING NO. SMA 07LV1-TGN

DRAWN	MARY	DATE	96.03.14
CHECKED	蘇姿潔	DATE	96.03.14
Q.A.	張育誌	DATE	
APPROVAL	馮健華	DATE	
REVISION		DATE	

DIMENSIONS ARE IN MILLIMETERS			
UNLESS OTHERWISE SPECIFIED TOLERANCE			
0.5-5=±0.2	120-315=±1		
5-30=±0.4	315-1000=±1.6		
30-120±0.6	1000-2000=±2.4		
SCALE	4:1	SIZE	A

REVISION	
DESCRIPTION	ENGINEER