

NO	DESCRIPTION	MATERIAL	Q'TY	FINISH	REMARK
1	BODY	BRASS	1	NICKEL	B-SMA0043-N
2	GASKET	SI RUBBER	1	RUBBER	RU-0008
3	INSULATION	TEFLON	1	TEFLON	I-0132T
4	WASHER	PH. BRONZE	1	GOLD	W-0012
5	BODY	BE CU	1	GOLD	B-SMA0094-N
6	PIN	BRASS	1	GOLD	P-SMA0062-G

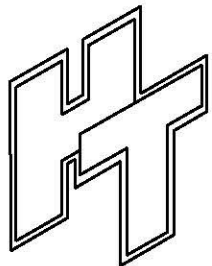
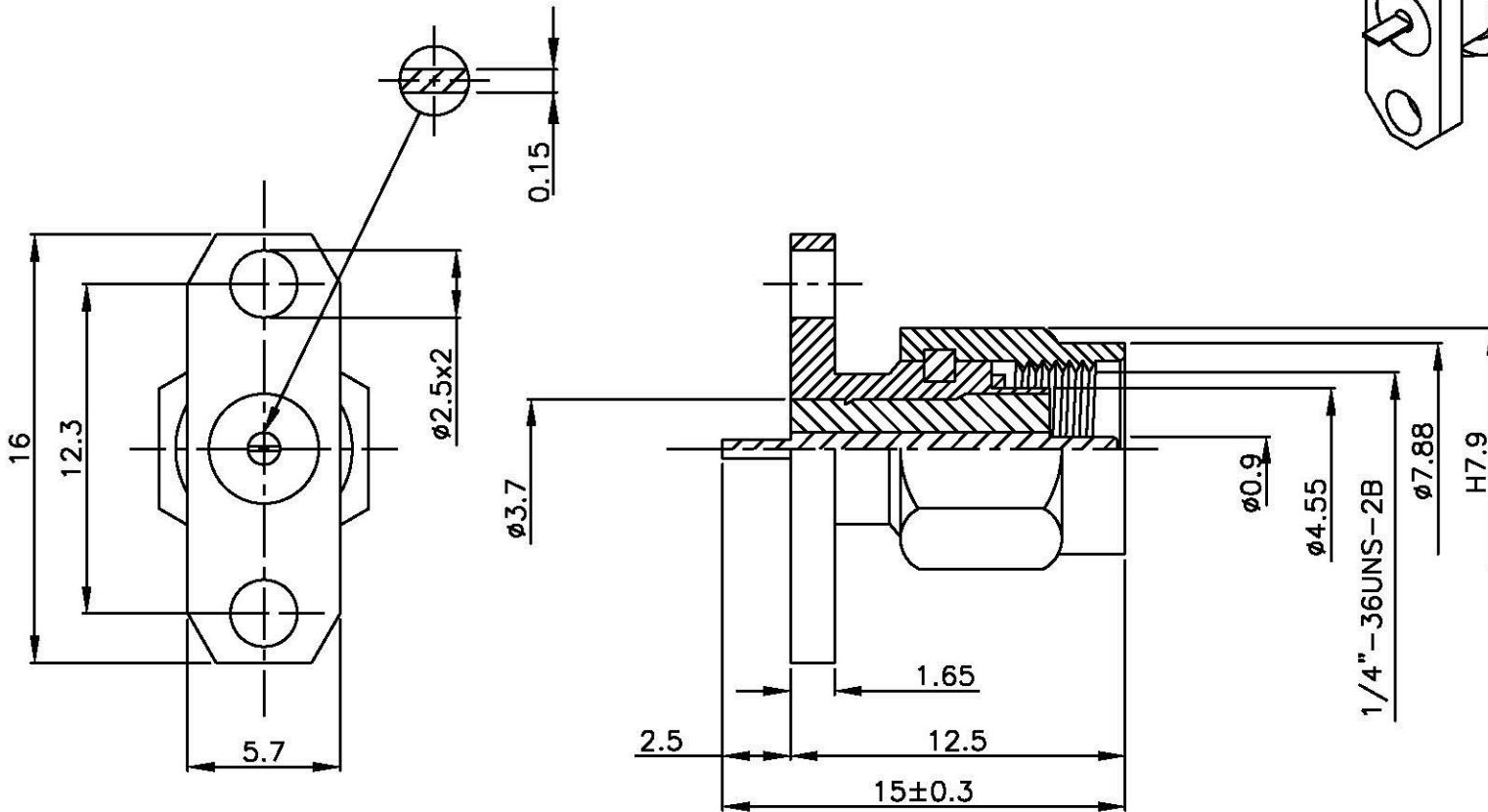
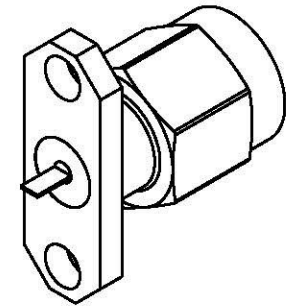

Allconnectors

www.allconnectors.de
Tel: +49 89 731 9094-11
info@allconnectors.de
Fax: +49 89 731 9094-10
Allconnectors - Germany
Karl-Wilhelm-Str. 26

TITLE SMA FEMALE PANEL RECEPTACLE
SOLDER FOR RG 405 (.085)

PART NO. SMA-06V5-TGN

DRAWING NO. SMA 06V5 TGN

DRAWN MARY DATE 96.03.15

CHECKED 黄巧君 DATE

Q.A. 蘇姿潔 DATE

APPROVAL 徐燦霖 DATE

REVISION DATE

DIMENSIONS ARE IN MILLIMETERS

UNLESS OTHERWISE SPECIFIED
TOLERANCES

0.5-5 = ± 0.2 120-315 = ± 1
5-30 = ± 0.4 315-1000 = ± 1.6
30-120 = ± 0.6 1000-2000 = ± 2.4

SCALE 5:1 SIZE A

REVISION

DESCRIPTION ENGINEER