

NO	DESCRIPTION	MATERIAL	Q'TY	FINISH	REMARK
1	SHELL	BRASS	1	GOLD	B-SMA0043-G
2	GASKET	SI RUBBER	1	RUBBER	RU-0008
3	INSULATION	TEFLON	1	TEFLON	I-0235T
4	WASHER	PH.BRONZE	1	GOLD	W-0012
5	BODY	BRASS	1	GOLD	B-SMA0104-G
6	PIN	BRASS	1	GOLD	P-SMA0095-G

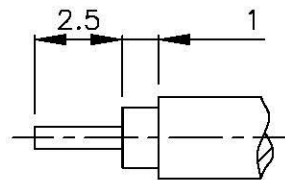

(Recommended Stripping Dimension)

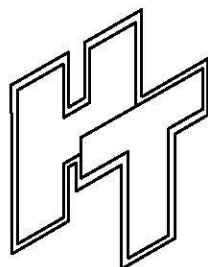
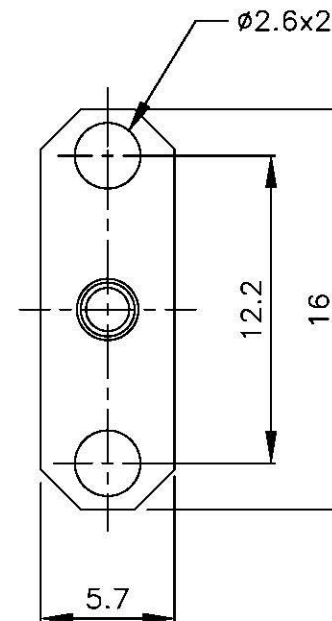
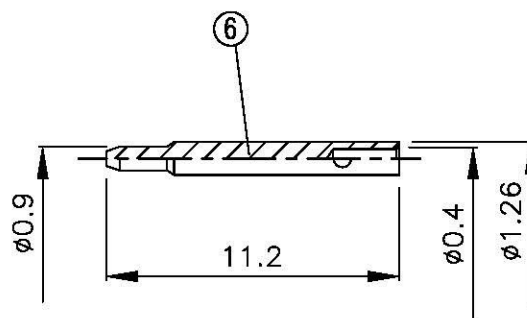
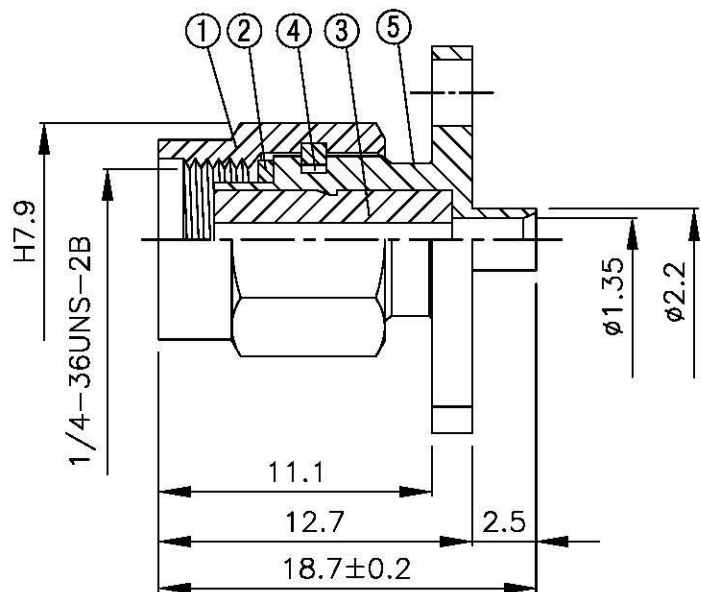
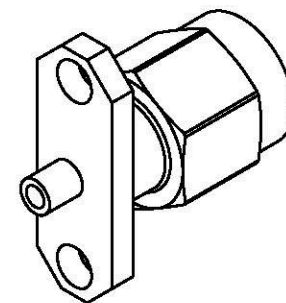

All Connectors

www.allconnectors.de
 TEL: 0049 711 7507501
 20201 Friedland - Germany

info@allconnectors.de
 TEL: 0049 711 7507501
 20201 Friedland - Germany

TITLE SMA MALE PANEL SOLDER FOR M17/151 (.047)

PART NO. SMA-06V3-TGG

DRAWING NO. SMA 06V3 TGG

DRAWN MARY DATE 96.03.15

CHECKED 黃巧君 DATE

Q.A. 蘇姿潔 DATE

APPROVAL 徐燦霖 DATE

REVISION DATE

DIMENSIONS ARE IN MILLIMETERS

UNLESS OTHERWISE SPECIFIED TOLERANCE

0.5-5=±0.2	120-315=±1
5-30=±0.4	315-1000=±1.6
30-120±0.6	1000-2000=±2.4

SCALE 4:1 SIZE A

REVISION

DESCRIPTION	ENGINEER