

NO	DESCRIPTION	MATERIAL	Q'TY	FINISH	REMARK
1	SHELL	BRASS	1	GOLD	B-SMA0043-G
2	GASKET	SI RUBBER	1	RUBBER	RU-0008
3	INSULATION	TEFLON	1	TEFLON	I-0235T
4	WASHER	PH.BRONZE	1	GOLD	W-0012
5	BODY	BRASS	1	GOLD	
6	PIN	BE CU	1	GOLD	P-SMA0058-G
7	RING	BRASS	1	GOLD	R-0007-G

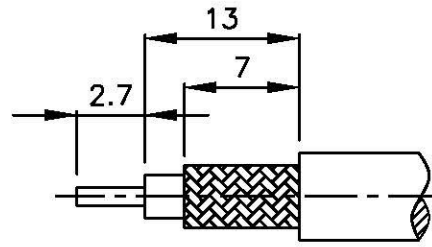

(Recommended Stripping Dimension)

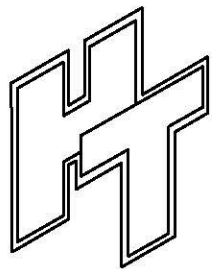
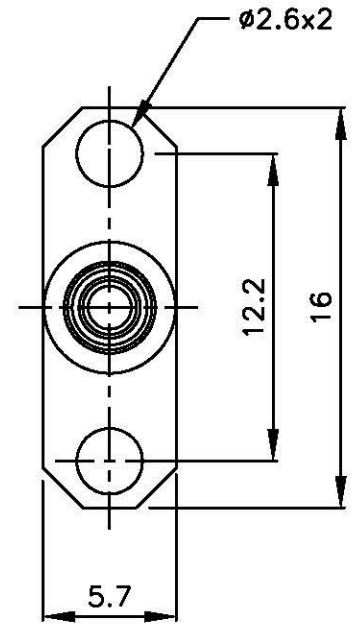
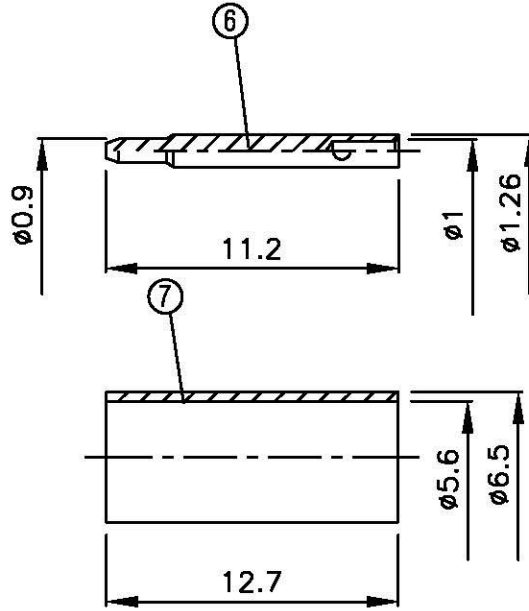
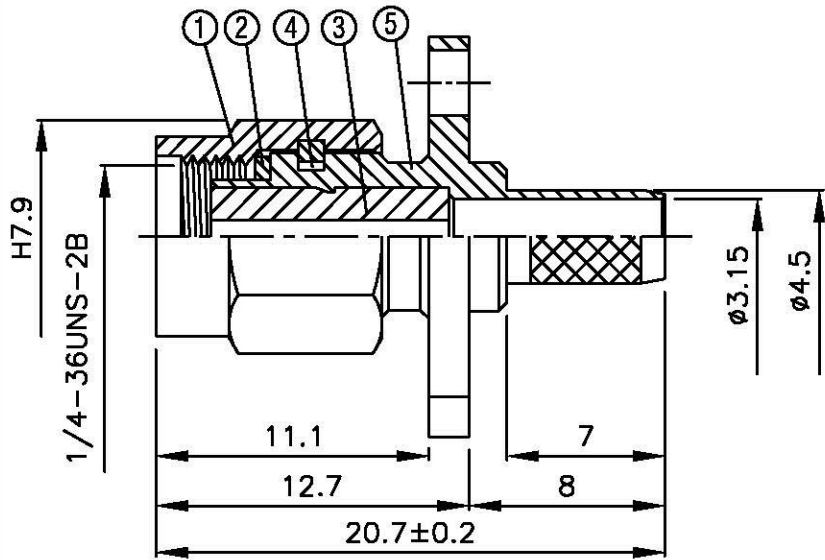
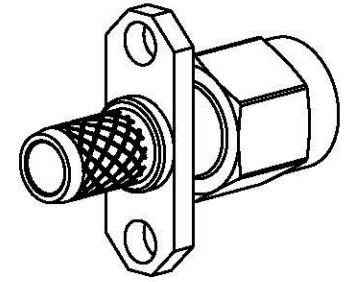

All Connectors

www.allconnectors.com.cn
Tel: 0049 711 7509368
70794 Pfladerstadt, Germany

en:allconnectors.com.cn
Fax: 0049 711 7509304
Kellernstr. 25

TITLE SMA MALE PANEL CRIMP FOR RG 58/U

PART NO. SMA-06F-TGG

DRAWING NO. SMA 06F TGG

DRAWN	MARY	DATE	96.03.15
CHECKED	黄巧君	DATE	
Q.A.	蘇姿潔	DATE	
APPROVAL	徐燦霖	DATE	
REVISION		DATE	

DIMENSIONS ARE IN MILLIMETERS			
UNLESS OTHERWISE SPECIFIED TOLERANCE			
0.5-5=±0.2	120-315=±1		
5-30=±0.4	315-1000=±1.6		
30-120±0.6	1000-2000=±2.4		

SCALE 4:1 SIZE A

REVISION

DESCRIPTION	ENGINEER