

NO	DESCRIPTION	MATERIAL	Q'TY	FINISH	REMARK
1	NUT	BRASS	1	NICKEL	N-0006
2	WASHER	BRASS	1	NICKEL	W-0016
3	GASKET	SI RUBBER	1	RUBBER	RU-0014
4	INSULATION	TEFLON	1	TEFLON	I-0131T
5	BODY	BRASS	1	NICKEL	B-SMA0093-N
6	PIN	BE CU	1	GOLD	P-SMA0064-G

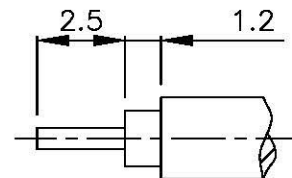

(Recommended Stripping Dimension)

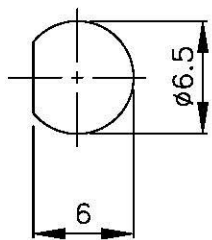
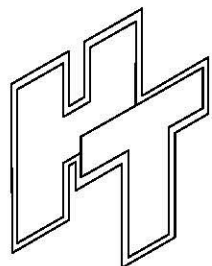
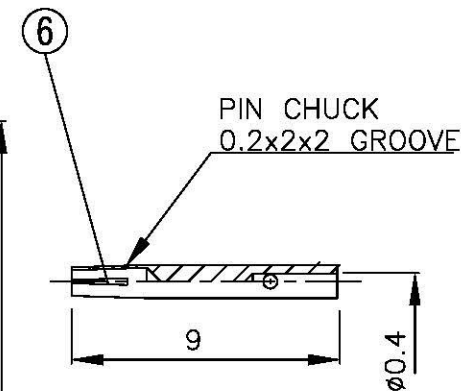
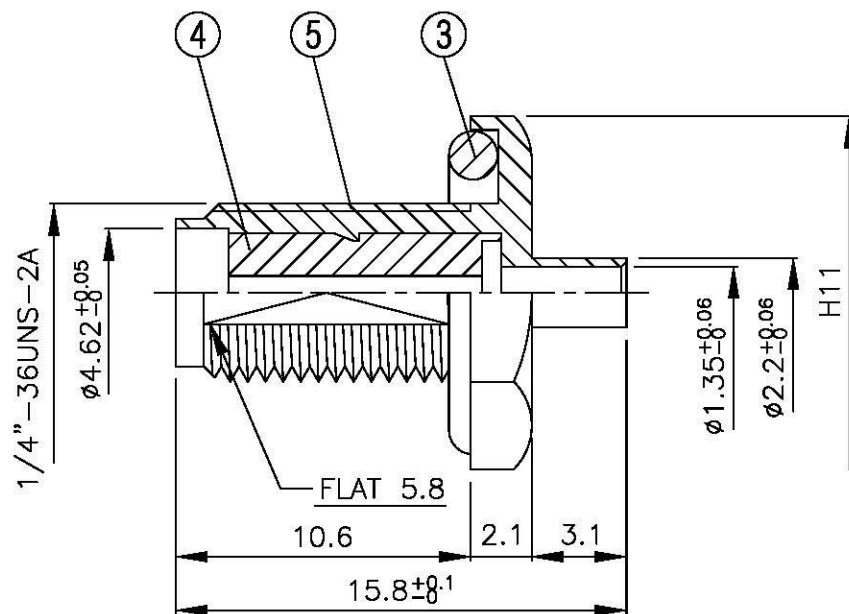
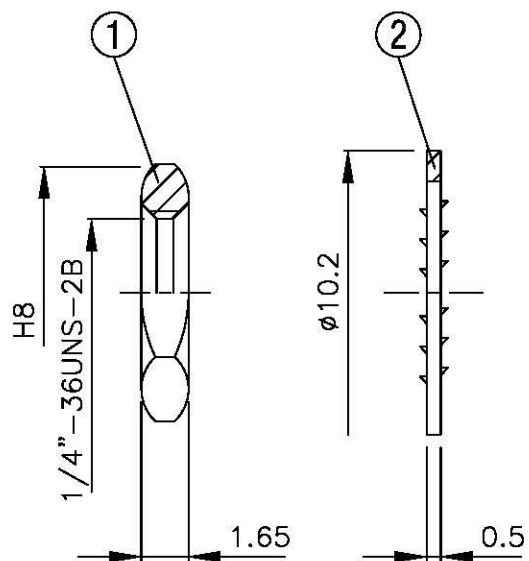
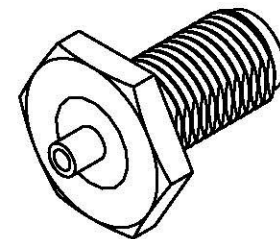

All Connectors

www.allconnectors.de
 info@allconnectors.de
 43714 Hildenstadt - Germany
 Fax: 0049 211 906204
 Kettelerstr. 25

TITLE SMA FEMALE SOLDER FOR M17/151 (.047)

PART NO. SMA-05V3-TGN

DRAWING NO. SMA 05V3 TGN

DRAWN MARY DATE 96.03.15

CHECKED 蘇姿潔 DATE

Q.A. 馮健華 DATE

APPROVAL 徐燦霖 DATE

REVISION DATE

DIMENSIONS ARE IN MILLIMETERS

UNLESS OTHERWISE SPECIFIED TOLERANCE

0.5-5=±0.2	120-315=±1
5-30=±0.4	315-1000=±1.6
30-120±0.6	1000-2000=±2.4

SCALE 4:1 SIZE A

REVISION

DESCRIPTION	ENGINEER