

NO	DESCRIPTION	MATERIAL	Q'TY	FINISH	REMARK
1	NUT	BRASS	1	GOLD	N-0006
2	WASHER	BRASS	1	GOLD	W-0016
3	GASKET	SI RUBBER	1	RUBBER	RU-0014
4	INSULATION	TEFLON	1	TEFLON	I-0131T
5	BODY	BRASS	1	GOLD	B-SMA0092-G
6	PIN	BRASS	1	GOLD	P-SMA0057-G

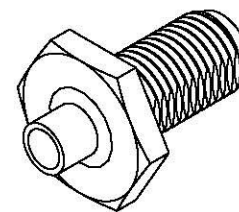

(Recommended Stripping Dimension)

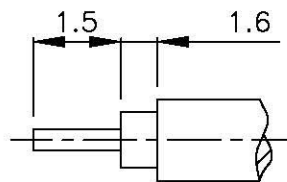
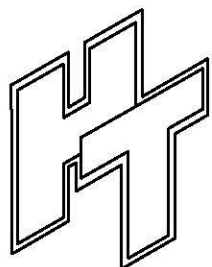
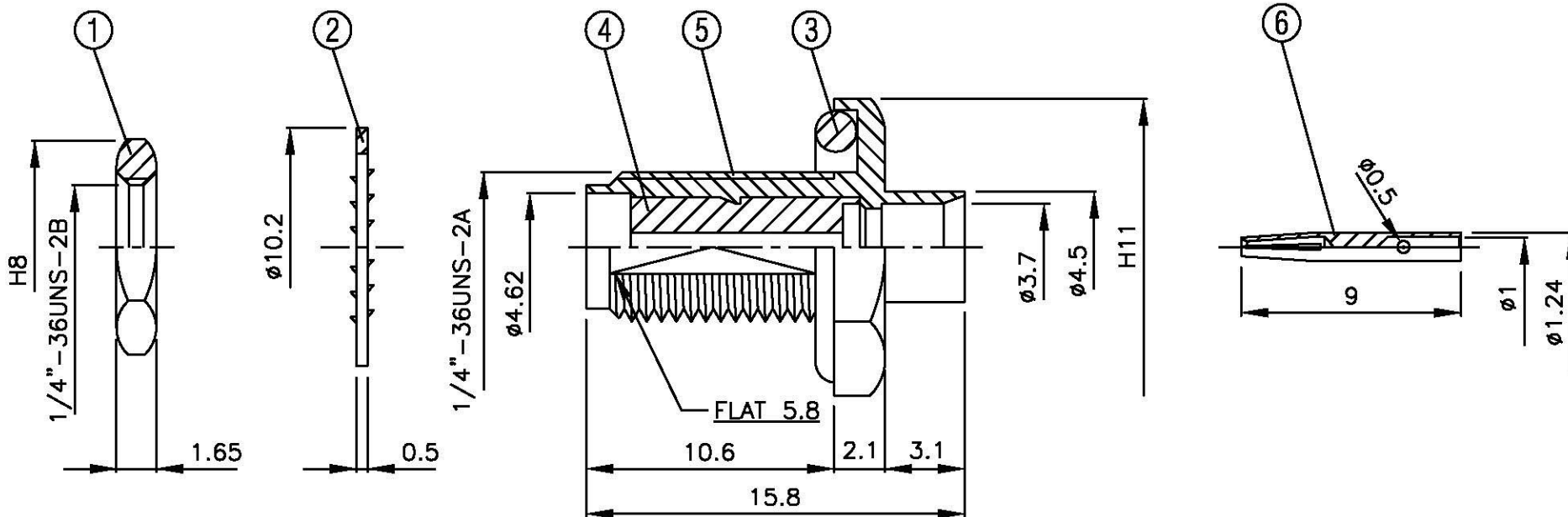

All Connectors

www.allconnectors.de
 Tel: 0049 711 7000972
 40342 Krefeld, Germany

Info@allconnectors.de
 Fax: 0049 711 7000974
 Krefeld, Germany

TITLE SMA FEMALE SOLDER FOR RG402U (.141)

PART NO. SMA-05V2-TGG

DRAWING NO. SMA 05V2 TGG

DRAWN MARY DATE 96.02.06

CHECKED 黄巧君 DATE

Q.A. 蘇姿潔 DATE

APPROVAL 徐燦霖 DATE

REVISION DATE

DIMENSIONS ARE IN MILLIMETERS

UNLESS OTHERWISE SPECIFIED TOLERANCE

0.5-5=±0.2	120-315=±1
5-30=±0.4	315-1000=±1.6
30-120±0.6	1000-2000=±2.4

SCALE 4:1 SIZE A

REVISION

DESCRIPTION	ENGINEER