

NO	DESCRIPTION	MATERIAL	QTY	FINISH	REMARK
1	NUT	BRASS	1	GOLD	N-0006-G
2	WASHER	BRASS	1	GOLD	W-0016-G
3	GASKET	SI RUBBER	1	RUBBER	RU-0014
4	INSULATION	TEFLON	1	TEFLON	I-0131T
5	BODY	BRASS	1	GOLD	B-SMA0091-G
6	PIN	BE CU	1	GOLD	P-SMA0056-G

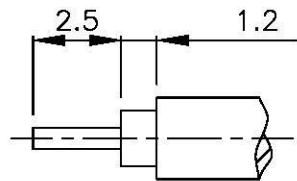

(Recommended Stripping Dimension)

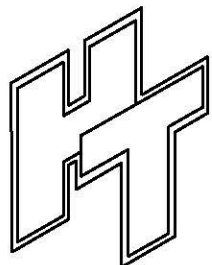
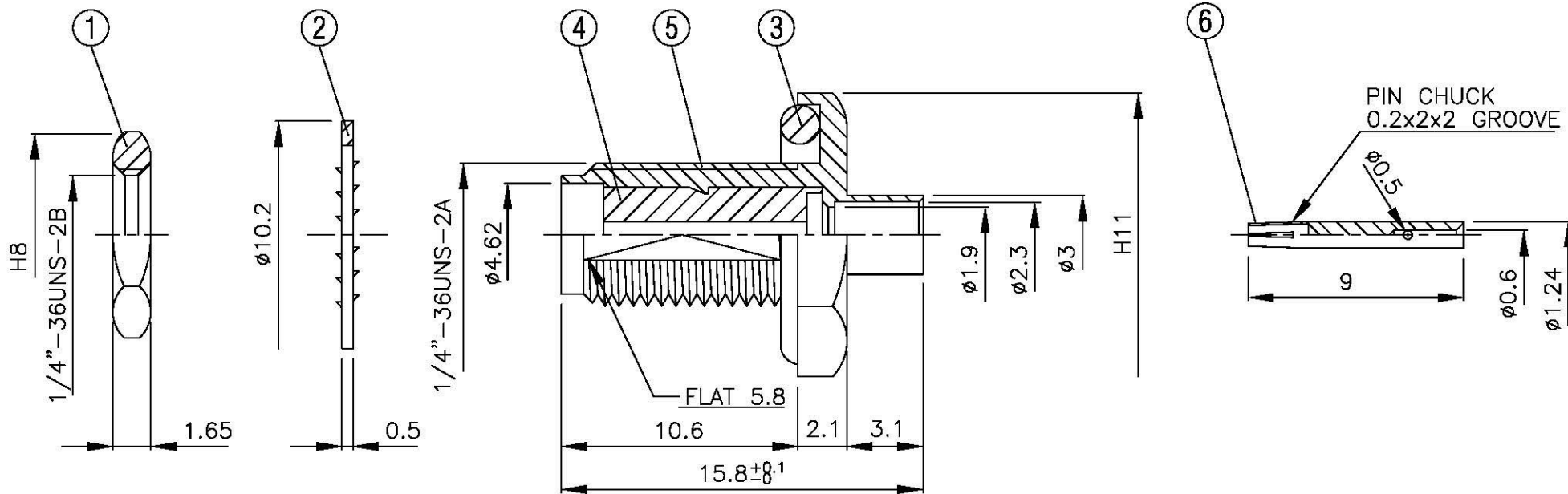
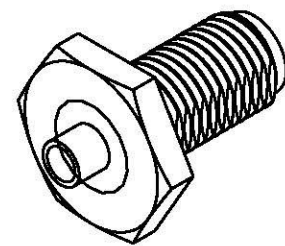

All Connectors
 www.allconnectors.de
 info@allconnectors.de
 Tel.: 0049 711 7005020 Fax: 0049 711 7005000
 70794 Filderstadt - Germany Kettenwegstr. 25

TITLE SMA FEMALE SOLDER FOR RG-405/U (.085)

PART NO. SMA-05V1-TGG

DRAWING NO. SMA 05V1 TGG

DRAWN	MARY	DATE	96.03.29
CHECKED	黄巧君	DATE	96.03.29
Q.A.	蘇姿潔	DATE	
APPROVAL	徐燦霖	DATE	
REVISION		DATE	

DIMENSIONS ARE IN MILLIMETERS			
UNLESS OTHERWISE SPECIFIED TOLERANCE			
0.5-5=±0.2	120-315=±1		
5-30=±0.4	315-1000=±1.6		
30-120±0.6	1000-2000=±2.4		

SCALE 4:1 SIZE A

REVISION	
DESCRIPTION	ENGINEER