

NO	DESCRIPTION	MATERIAL	Q'TY	FINISH	REMARK
1	NUT	BRASS	1	GOLD	N-0006-G
2	WASHER	BRASS	1	GOLD	W-0016-G
3	GASKET	SI RUBBER	1	RUBBER	RU-0014
4	INSULATION	TEFLON	1	TEFLON	I-0131T
5	BODY	BRASS	1	GOLD	B-SMA0205-G
6	PIN	BE CU	1	GOLD	P-SMA0635-G
7	INSULATION	TEFLON	1	TEFLON	I-0256T
8	BODY	BRASS	1	GOLD	B-SMA0902-G

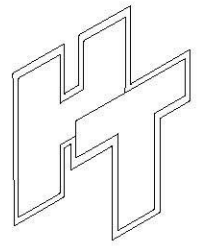
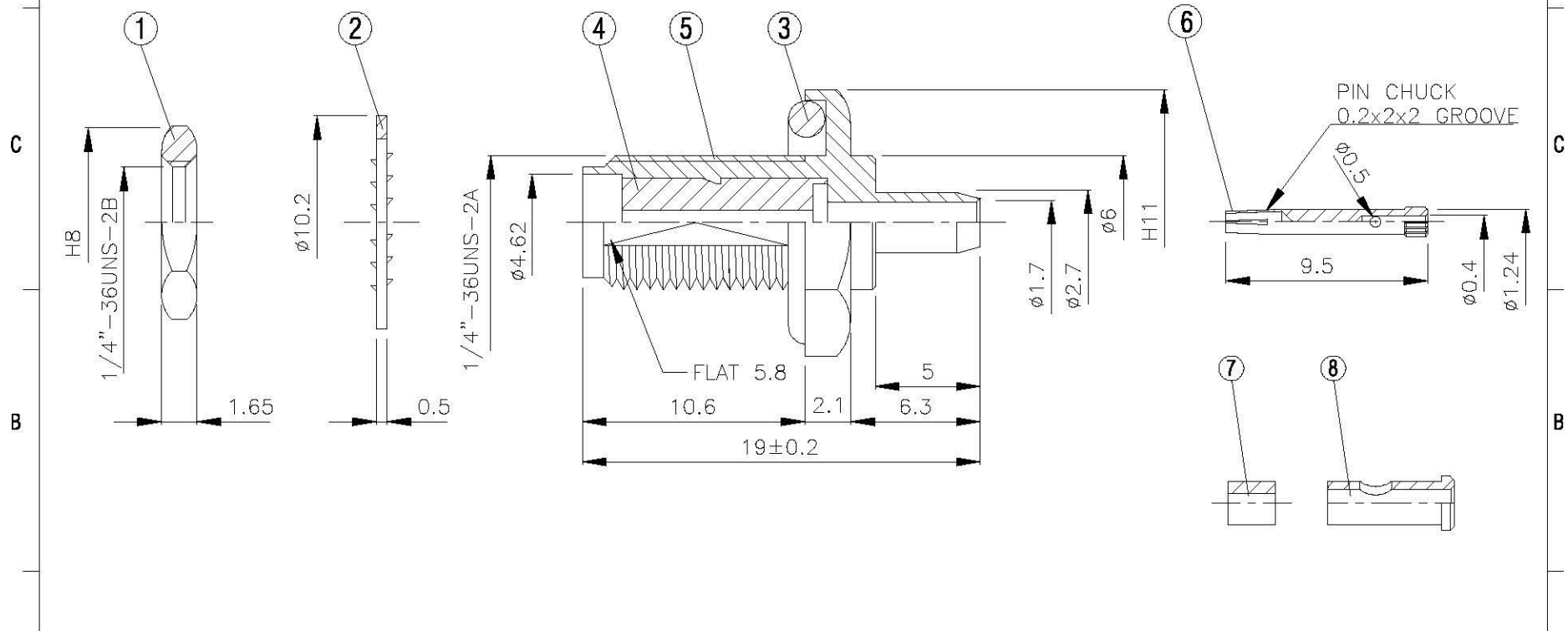
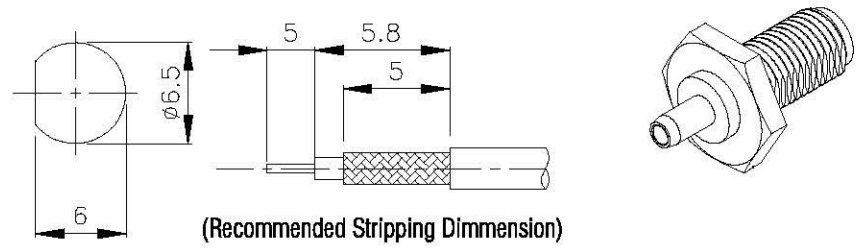

All Connectors
 info@allconnectors.de
 Tel.: 0049 211 7009363
 70704 Filberstadt - Germany

info@allconnectors.de
 Fax: 0049 211 7009364
 Kistnerstr. 25

TITLE SMA FEMALE CRIMP FOR HRS 1.1mm

PART NO. SMA-05U1-TGG

DRAWING NO. SMA 05U1 TGG

DRAWN MARY

CHECKED 蘇姿潔

Q.A. 馮健華

APPROVA 徐燦霖

REVISION

DATE 96.03.15

DATE

DATE

DATE

DATE

DIMENSIONS ARE IN MILLIMETERS

UNLESS OTHERWISE SPECIFIED TOLERANCE

0.5-5=±0.2 120-315=±1

5-30= ±0.4 315-1000=±1.6

30-120=±0.6 1000-2000=±2.4

SCALE 4:1 SIZE A

REVISION	
DESCRIPTION	ENGINEER