

NO	DESCRIPTION	MATERIAL	Q'TY	FINISH	REMARK
1	BODY	BRASS	1	GOLD	B-SMA0064-G
2	INSULATION	TEFLON	1	TEFLON	I-0547T
3	PIN	Be Cu	1	GOLD	P-SMA0038-G

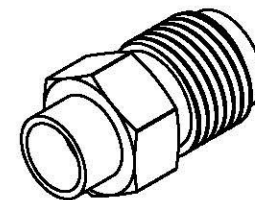

(Recommended Stripping Dimension)

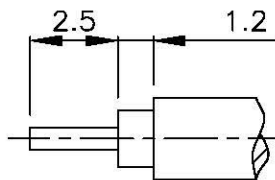
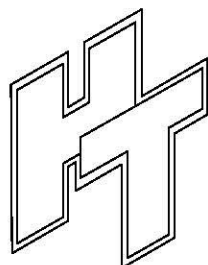
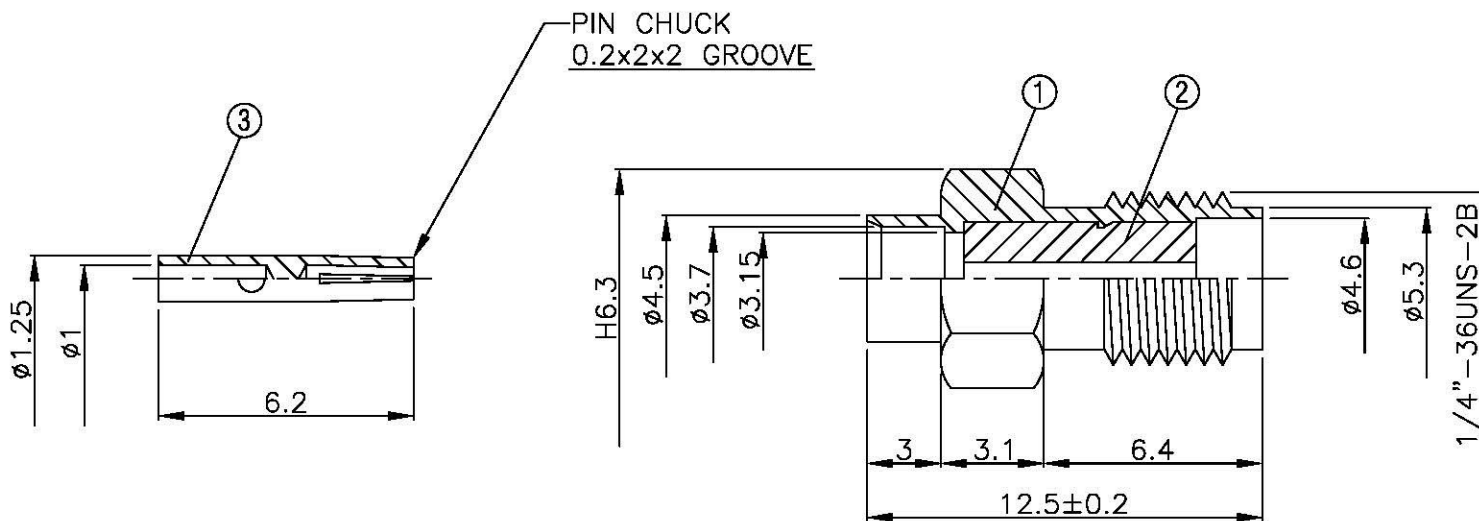

All Connectors

www.allconnectors.de info@allconnectors.de
tel.: 0049 723 4805840 fax: 0049 711 7022601
70724 Ulm - Germany

TITLE SMA FEMALE SOLDER FOR RG 402 (.141)

PART NO. SMA-04V2-TGG

DRAWING NO. SMA 04V2 TGG

DRAWN MARY DATE 96.03.25

CHECKED 黄巧君 DATE

Q.A. 蘇姿潔 DATE

APPROVAL 徐燦霖 DATE

REVISION DATE

DIMENSIONS ARE IN MILLIMETERS

UNLESS OTHERWISE SPECIFIED TOLERANCES

0.5-5=±0.2 120-315=±1
5-30=±0.4 315-1000=±1.6
30-120=±0.6 1000-2000=±2.4

SCALE 4:1 SIZE A

REVISION

DESCRIPTION ENGINEER

4

3

2

1

A