

NO	DESCRIPTION	MATERIAL	Q'TY	FINISH	REMARK
1	BODY 1	BRASS	1	GOLD	B-SMA0209-G
2	INSULATION 1	TEFLON	1	TEFLON	I-0547T
3	PIN	Be Cu	1	GOLD	P-SMA0120-G
4	INSULATION 2	TEFLON	1	TEFLON	I-0229T
5	BODY 2	BRASS	1	GOLD	B-SMA0903-G

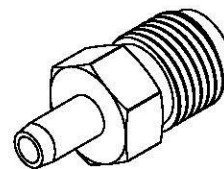

(Recommended Stripping Dimension)

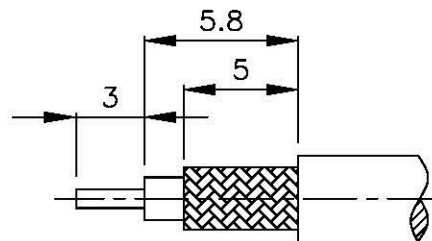
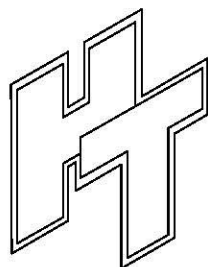
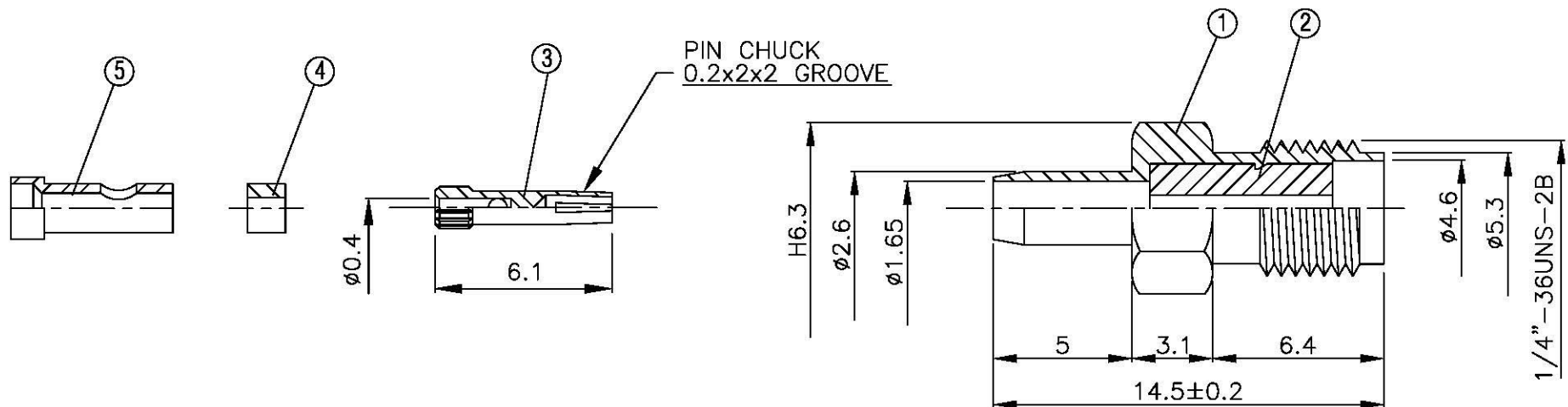

All Connectors

www.allconnectors.de
Tel: 0049 711 506505
info@allconnectors.de
Fax: 0049 711 730594
All Connectors GmbH - Germany
Kollmannstr. 2b

TITLE SMA FEMALE CRIMP
FOR HRS 0.8mm

PART NO. SMA-04U2-TGG

DRAWING NO. SMA 04U2 TGG

DRAWN MARY DATE 96.04.09

CHECKED 蘇姿潔 DATE

Q.A. 馮健華 DATE

APPROVAL 徐燦霖 DATE

REVISION DATE

DIMENSIONS ARE IN MILLIMETERS

UNLESS OTHERWISE SPECIFIED
TOLERANCES

0.5-5=±0.2 120-315=±1

5-30=±0.4 315-1000=±1.6

30-120=±0.6 1000-2000=±2.4

SCALE 4:1 SIZE A

REVISION

DESCRIPTION ENGINEER