

NO	DESCRIPTION	MATERIAL	Q'TY	FINISH	REMARK
1	BODY 1	BRASS	1	GOLD	B-SMA0209-G
2	INSULATION 1	TEFLON	1	TEFLON	I-0547T
3	PIN	Be Cu	1	GOLD	P-SMA0120-G
4	INSULATION 2	TEFLON	1	TEFLON	I-0229T
5	BODY 2	BRASS	1	GOLD	B-SMA0902-G

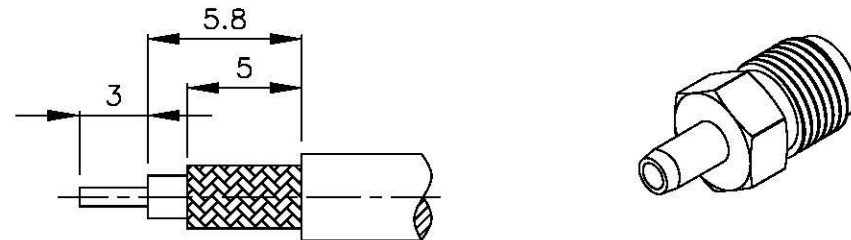

(Recommended Stripping Dimension)

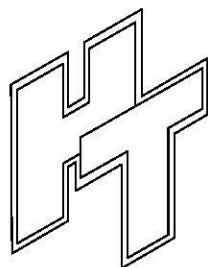
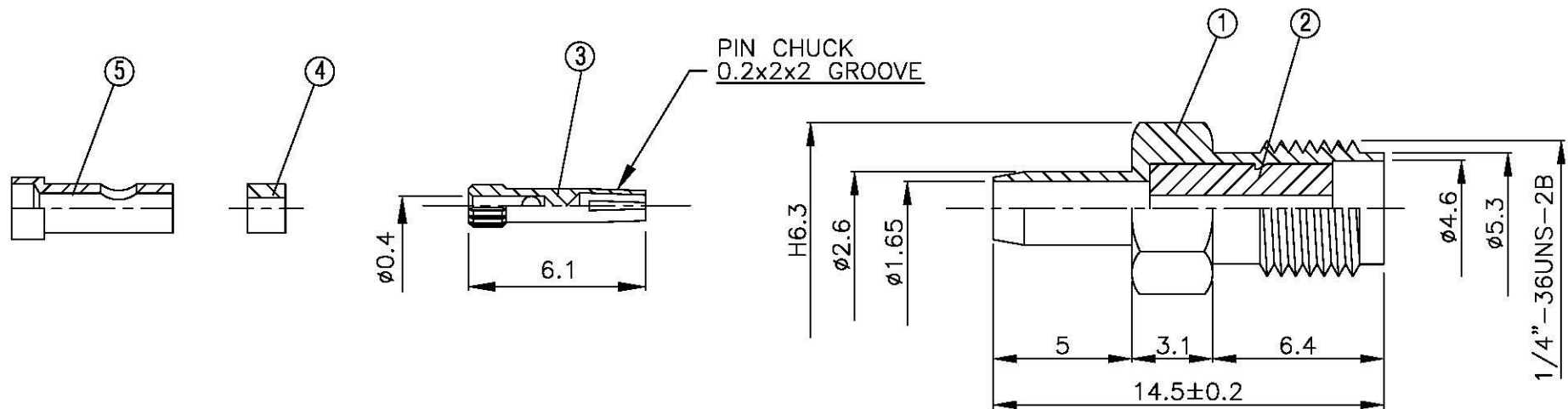

All Connectors

www.allconnectors.de info@allconnectors.de
 TEL: 0049 711 7009501 FAX: 0049 711 7009504
 20794 Fildarsbach - Germany kartamar@t-2k

TITLE SMA FEMALE CRIMP FOR HRS 1.1mm

PART NO. SMA-04U1-TGG

DRAWING NO. SMA 04U1 TGG

DRAWN MARY DATE 96.03.28

CHECKED 蘇姿潔 DATE

Q.A. 馮健華 DATE

APPROVAL 徐燦霖 DATE

REVISION DATE

DIMENSIONS ARE IN MILLIMETERS

UNLESS OTHERWISE SPECIFIED TOLERANCES

0.5-5=±0.2 120-315=±1
 5-30=±0.4 315-1000=±1.6
 30-120=±0.6 1000-2000=±2.4

SCALE 4:1 SIZE A

REVISION

DESCRIPTION ENGINEER

4

3

2

1

A