

NO	DESCRIPTION	MATERIAL	Q'TY	FINISH	REMARK
1	BODY 1	BRASS	1	GOLD	B-SMA0209-G
2	INSULATION 1	TEFLON	1	TEFLON	I-0547T
3	PIN	Be Cu	1	GOLD	P-SMA0120-G
4	INSULATION 2	TEFLON	1	TEFLON	I-0229T
5	BODY 2	BRASS	1	GOLD	B-SMA0902-G

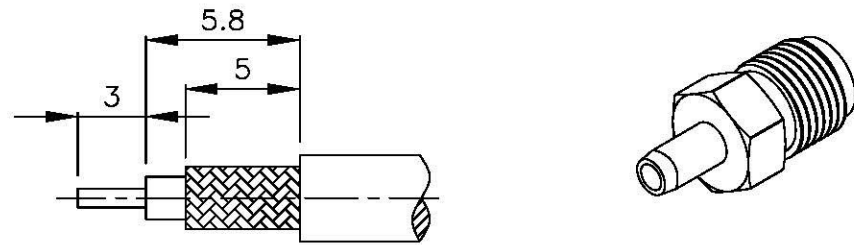

(Recommended Stripping Dimension)

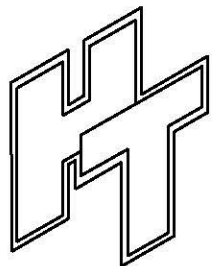
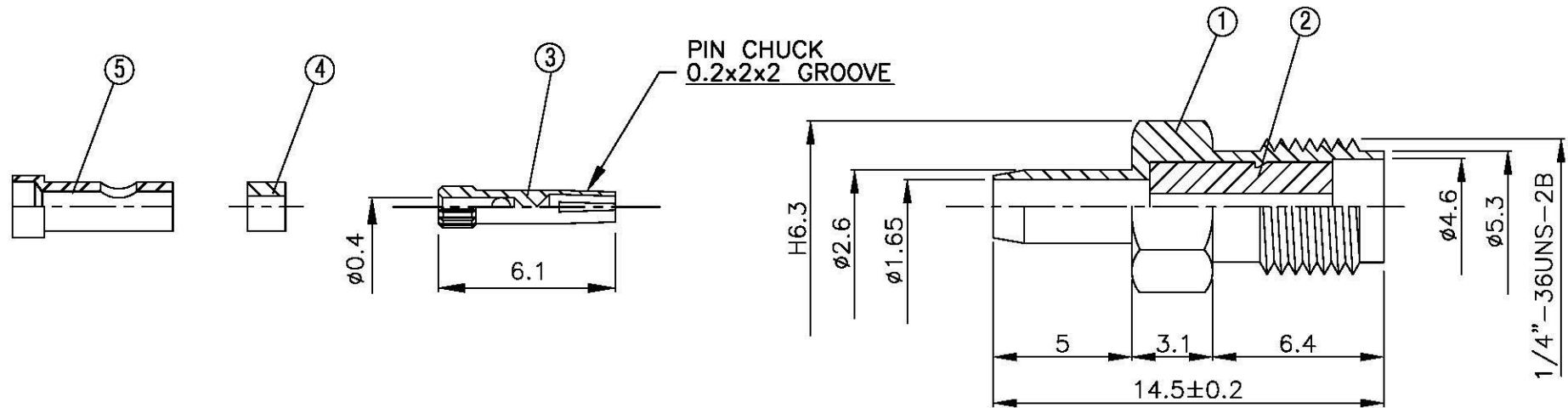

**All Connectors**

www.allconnectors.de  
Tel.: 0049 711 7009305  
70794 Rildorfstr. - Germany

info@allconnectors.de  
Fax: 0049 711 7009304  
Kettelerstr. 25

TITLE SMA FEMALE CRIMP  
FOR HRS 1.3mm

PART NO. SMA-04U-TGG

DRAWING NO. SMA 04U TGG

DRAWN MARY

DATE 96.03.27

CHECKED 蘇姿潔

DATE

Q.A. 馮健華

DATE

APPROVAL 徐燦霖

DATE

REVISION

DATE

DIMENSIONS ARE IN MILLIMETERS

UNLESS OTHERWISE SPECIFIED  
TOLERANCES

0.5-5=±0.2 120-315=±1

5-30=±0.4 315-1000=±1.6

30-120=±0.6 1000-2000=±2.4

SCALE 4:1 SIZE A

REVISION

DESCRIPTION ENGINEER