

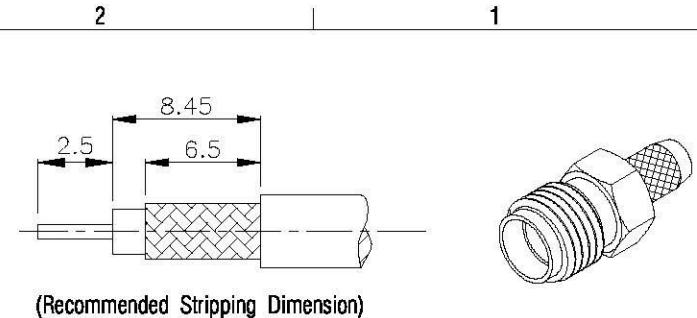

NO	DESCRIPTION	MATERIAL	Q'TY	FINISH	REMARK
1	BODY	BRASS	1	GOLD	B-SMA0061-G
2	INSULATION	TEFLON	1	TEFLON	I-0547T
3	PIN	Be Cu	1	GOLD	P-SMA0038-G
4	RING	BRASS	1	GOLD	R-0047-G

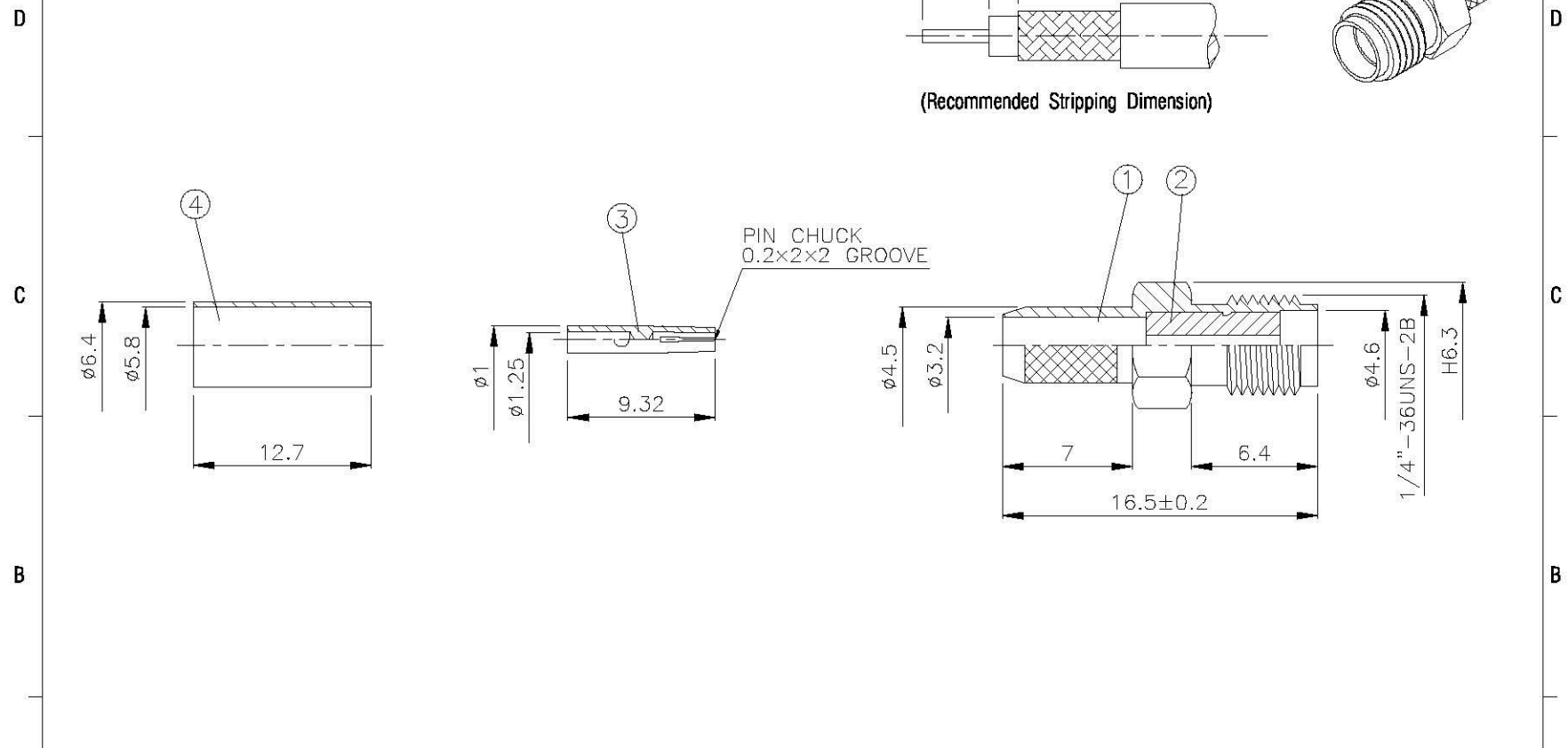

(Recommended Stripping Dimension)

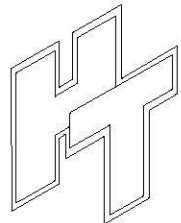

			DRAWN MARY	DATE 96.03.30	DIMENSIONS ARE IN MILLIMETERS UNLESS OTHERWISE SPECIFIED TOLERANCES		REVISION	
	<small>www.allconnectors.de Tel: 0049 711 900503 70704 Filzschmitt - Germany</small>		CHECKED 蘇姿潔	DATE			DESCRIPTION	ENGINEER
	TITLE SMA FEMALE CRIMP FOR RG142/U, RG400/U		Q.A. 馮健華	DATE	0.5-5=±0.2 120-315=±1			
	PART NO. SMA-04FA-TGG		APPROVAL 徐煥霖	DATE	5-30=±0.4 315-1000=±1.6			
	DRAWING NO. SMA 04FA TGG		REVISION	DATE	30-120=±0.6 1000-2000=±2.4			
				SCALE 4:1	SIZE A			