

NO	DESCRIPTION	MATERIAL	Q'TY	FINISH	REMARK
1	BODY	BRASS	1	GOLD	B-SMA0061-N
2	INSULATION	TEFLON	1	TEFLON	I-0547T
3	PIN	Be Cu	1	GOLD	P-SMA0038-G
4	RING	BRASS	1	GOLD	R-0007-N

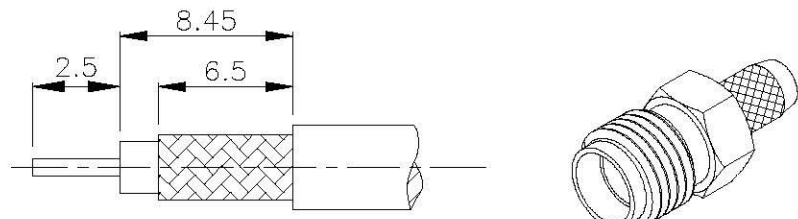

(Recommended Stripping Dimension)

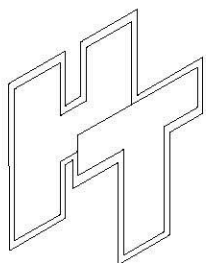
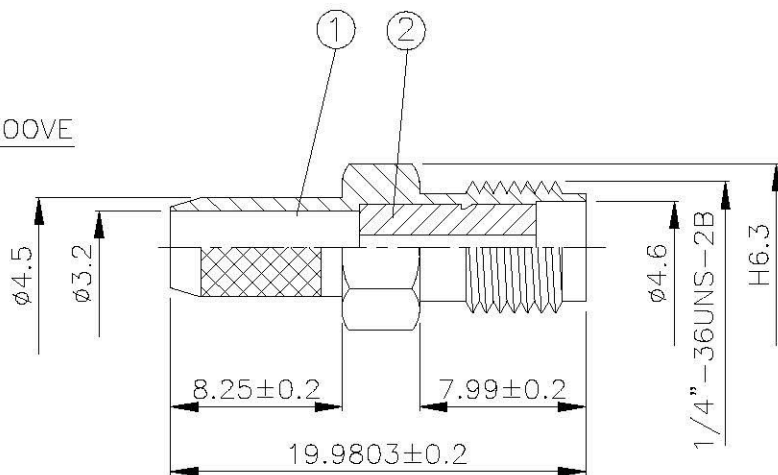
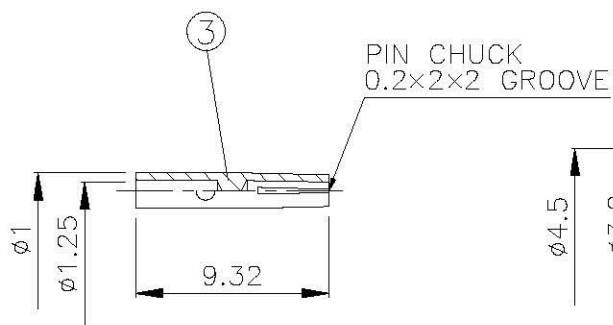
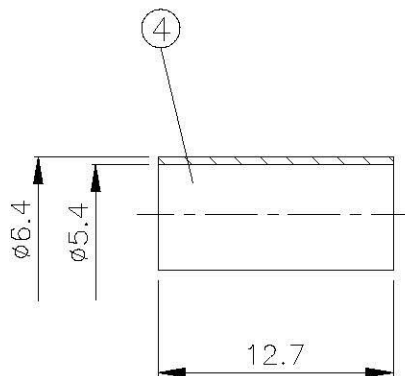

All Connectors

www.allconnectors.de
 TEL: 0049 711 4884411
 70294 Filderstadt, Germany

info@allconnectors.de
 Fax: 0049 711 400264
 Rottmannerstr. 25

TITLE SMA FEMALE CRIMP
 FOR RG58U, RG141A/U

PART NO. SMA-04F-TGN

DRAWING NO. SMA 04F TGN

DRAWN MARY DATE 90.10.23

CHECKED 蘇姿潔 DATE

Q.A. 馮健華 DATE

APPROVAL 徐燦霖 DATE

REVISION DATE

DIMENSIONS ARE IN MILLIMETERS

UNLESS OTHERWISE SPECIFIED
 TOLERANCES

0.5-5=±0.2 120-315=±1

5-30=±0.4 315-1000=±1.6

30-120=±0.6 1000-2000=±2.4

SCALE 4:1 SIZE A

REVISION

DESCRIPTION ENGINEER

D

C

B

A

D

C

B

A

4

3

2

1