

NO	DESCRIPTION	MATERIAL	Q'TY	FINISH	REMARK
1	SHELL	BRASS	1	GOLD	B-SMA0043-G
2	GASKET	SI RUBBER	1	RUBBER	RU-0008
3	INSULATION	TEFLON	1	TEFLON	I-0115T
4	WASHER	PH.BRONZE	1	GOLD	W-0012
5	BODY	BRASS	1	GOLD	B-SMA0008-G
6	PIN	BRASS	1	GOLD	P-SMA0119-G

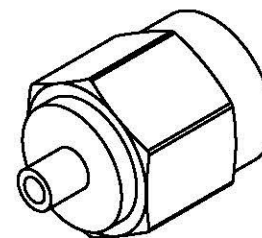

(Recommended Stripping Dimension)

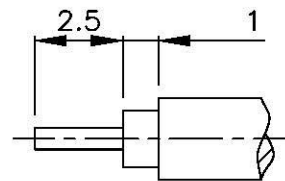
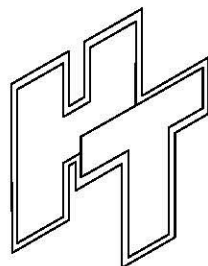
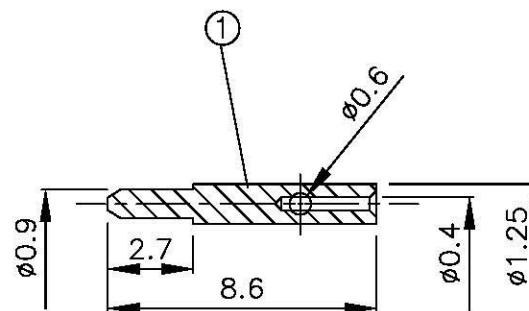
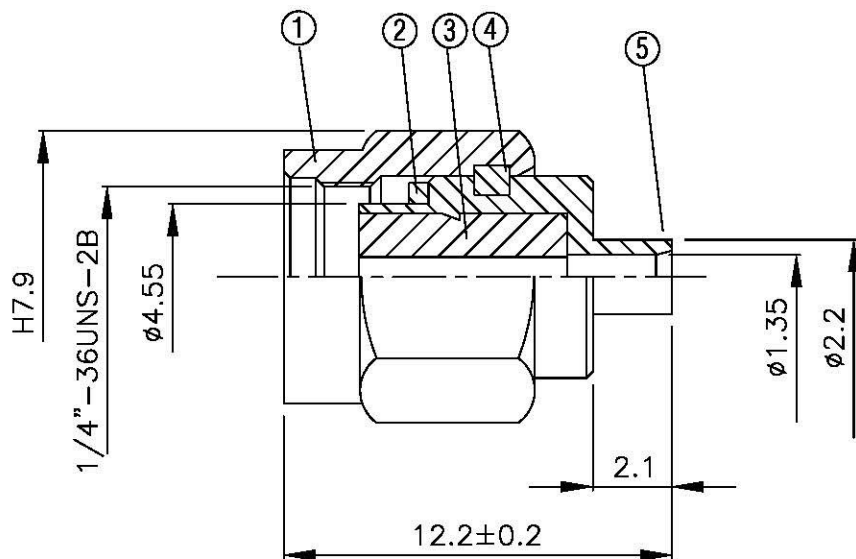

All Connectors
 10000 All Connectors Ave
 11111 11111 11111
 11111 1111111111 - 1111111111

TITLE SMA MALE SOLDER FOR FOR M17/151 (.047)

PART NO. SMA-03V3-TGG

DRAWING NO. SMA 03V3 TGG

DRAWN	MARY	DATE	96.03.29
CHECKED	蘇姿潔	DATE	
Q.A.	馮健華	DATE	
APPROVAL	徐燦霖	DATE	
REVISION		DATE	

DIMENSIONS ARE IN MILLIMETERS			
UNLESS OTHERWISE SPECIFIED TOLERANCE			
0.5-5=±0.2	120-315=±1		
5-30=±0.4	315-1000=±1.6		
30-120±0.6	1000-2000=±2.4		

SCALE	4:1	SIZE	A
-------	-----	------	---

REVISION

DESCRIPTION	ENGINEER