

NO	DESCRIPTION	MATERIAL	Q'TY	FINISH	REMARK
1	SHELL	BRASS	1	GOLD	B-SMA0043-G
2	GASKET	SI RUBBER	1	RUBBER	RU-0008
3	INSULATION	TEFLON	1	TEFLON	I-0115T
4	WASHER	PH.BRONZE	1	GOLD	W-0012
5	BODY	BRASS	1	GOLD	B-SMA0042-G
6	PIN	BRASS	1	GOLD	P-SMA0037-G

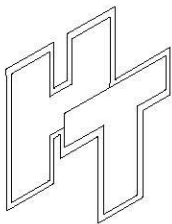
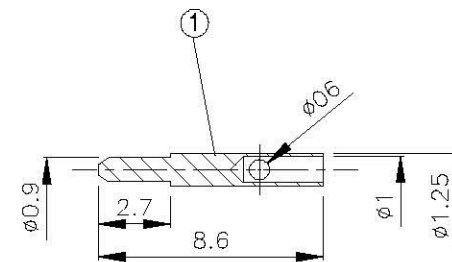
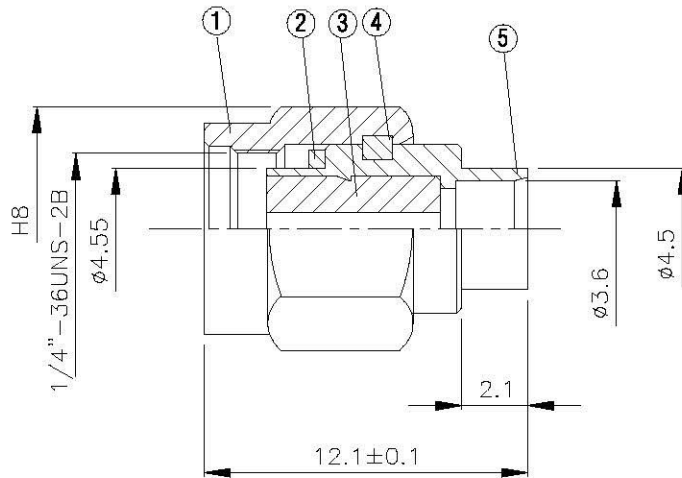
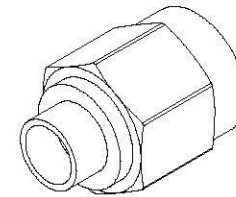
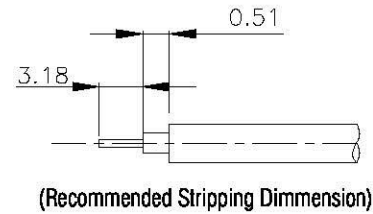

All Connectors

www.allconnectors.de
info@allconnectors.de
78794 Eßlingen - Germany

DRAWN MARY DATE 90.02.22

CHECKED 蘇志欣 DATE 97.07.02

Q.A. 蘇姿潔 DATE

APPROVAL 徐潔霖 DATE

REVISION DATE

TITLE SMA MALE SOLDER FOR RG402 (.141)

PART NO. SMA-03V2-TGG

DRAWING NO. SMA 03V2 TGG

DIMENSIONS ARE IN MILLIMETERS

UNLESS OTHERWISE SPECIFIED TOLERANCE

0.5-5=±0.2	120-315=±1
5-30=±0.4	315-1000=±1.6
30-120=±0.6	1000-2000=±2.4

SCALE 4:1 SIZE A

REVISION

DESCRIPTION	ENGINEER