

NO	DESCRIPTION	MATERIAL	Q'TY	FINISH	REMARK
1	SHELL	BRASS	1	NICKEL	B-SMA0043-N
2	GASKET	SI RUBBER	1	RUBBER	RU-0008
3	INSULATION	TEFLON	1	TEFLON	I-0115T
4	WASHER	SUS3003	1	GOLD	W-0012
5	BODY	BRASS	1	GOLD	B-SMA0044-G
6	PIN	BRASS	1	GOLD	P-SMA0040-G

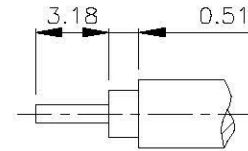

(Recommended Stripping Dimension)

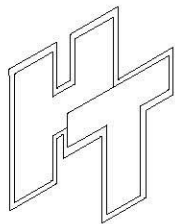
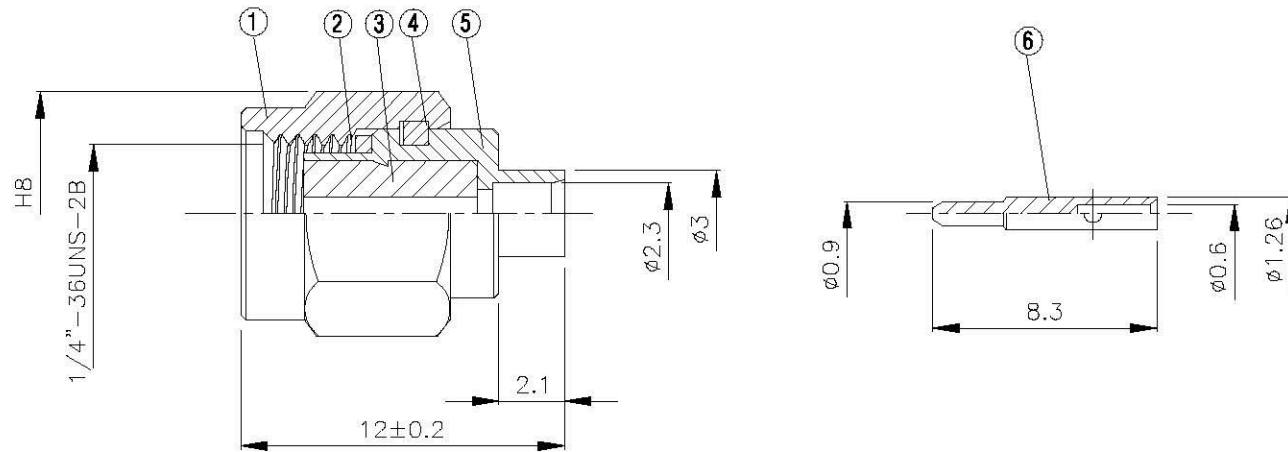
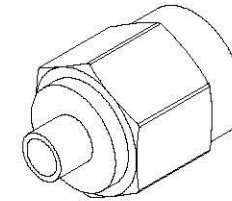

**All Connectors**

www.allconnectors.com  
TEL: 0649 211 789903  
www.hkconnectors.com.hk

info@allconnectors.com  
TEL: 0649 211 789903  
info@hkconnectors.com.hk

TITLE **SMA MALE SOLDER FOR RG405 (.085)**

PART NO. **SMA-03V1-TGG**

DRAWING NO. **SMA 03V1 TGG**

DRAWN **MARY** DATE **96.03.28**

CHECKED **蘇姿潔** DATE

Q.A. **馮健華** DATE

APPROVAL **徐燦霖** DATE

REVISION DATE

DIMENSIONS ARE IN MILLIMETERS

UNLESS OTHERWISE SPECIFIED TOLERANCE

0.5-5=±0.2    120-315=±1  
5-30=±0.4    315-1000=±1.6  
30-120=±0.6    1000-2000=±2.4

SCALE **4:1** SIZE **A**

REVISION

DESCRIPTION ENGINEER

4

3

2

1

D

D

C

C

B

B

A

A