

NO	DESCRIPTION	MATERIAL	Q'TY	FINISH	REMARK
1	SHELL	BRASS	1	GOLD	B-SMA0043-G
2	GASKET	SI RUBBER	1	RUBBER	RU-0008
3	INSULATION	TEFLON	1	TEFLON	I-0115T
4	WASHER	PH.BRONZE	1	GOLD	W-0012
5	BODY 1	BRASS	1	GOLD	B-SMA0208-G
6	PIN	BRASS	1	GOLD	P-SMA0119-G
7	INAULATION 2	TEFLON	1	TEFLON	I-0347T
8	BODY 2	BRASS	1	GOLD	B-SMA0902-G

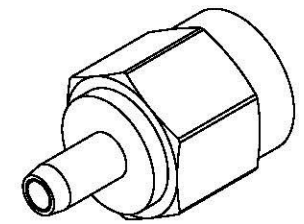

(Recommended Stripping Dimension)

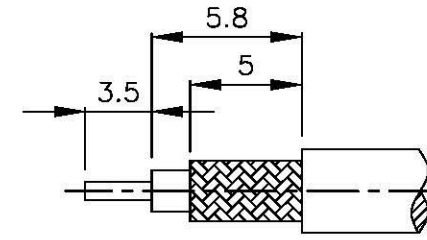
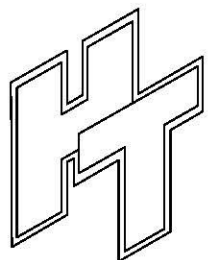
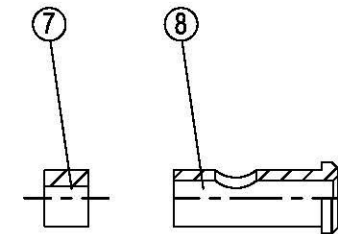
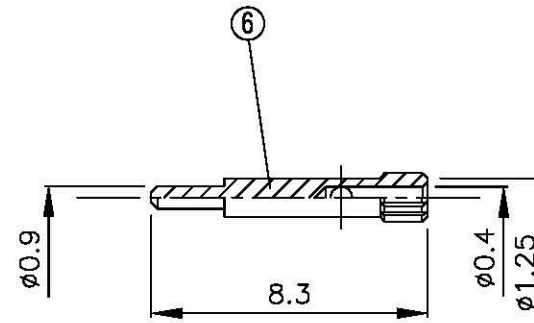
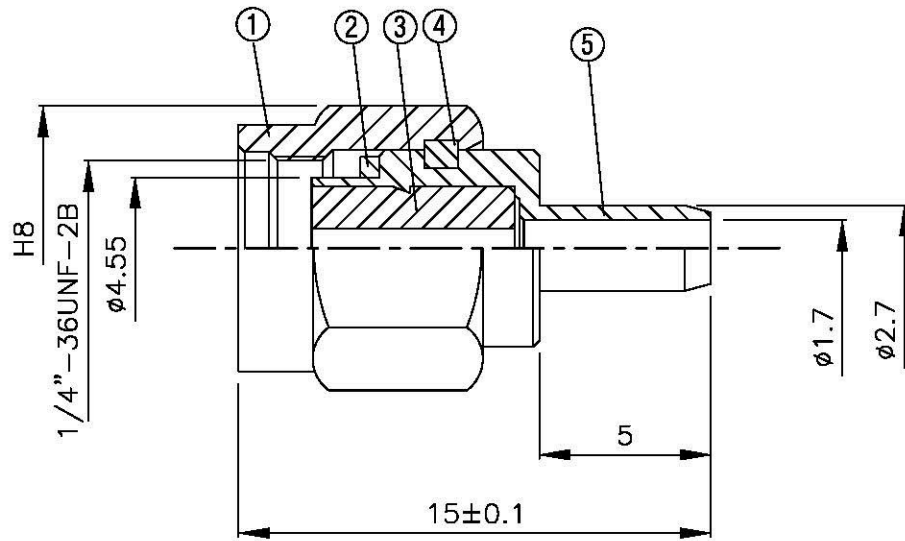

All Connectors

www.allconnectors.co
info@allconnectors.co

TITLE SMA MALE CRIMP FOR HRS 1.3mm

PART NO. SMA-03U-TGG

DRAWING NO. SMA 03U TGG

DRAWN MARY DATE 96.07.20

CHECKED 蘇志欣 DATE 97.05.20

Q.A. 蘇姿潔 DATE

APPROVAL 徐燦霖 DATE

REVISION DATE

DIMENSIONS ARE IN MILLIMETERS

UNLESS OTHERWISE SPECIFIED TOLERANCE
 0.5-5=±0.2 120-315=±1
 5-30= ±0.4 315-1000=±1.6
 30-120±0.6 1000-2000=±2.4

SCALE 4:1 SIZE A

REVISION

DESCRIPTION ENGINEER

D

C

B

A

D

C

B

A