

NO	DESCRIPTION	MATERIAL	Q'TY	FINISH	REMARK
1	SHELL	BRASS	1	NICKEL	B-SMA0043-N
2	GASKET	SI RUBBER	1	RUBBER	RU-0008
3	WASHER	BRASS	1	NICKEL	W-0012
4	INSULATION	TEFLON	1	TEFLON	I-0115T
5	BODY	BRASS	1	NICKEL	B-SMA0776-N
6	PIN	BRASS	1	GOLD	P-SMA0545-G
7	RING	BRASS	1	NICKEL	R-0064-N

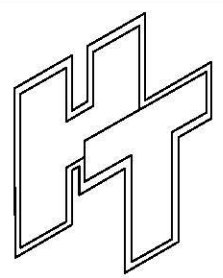
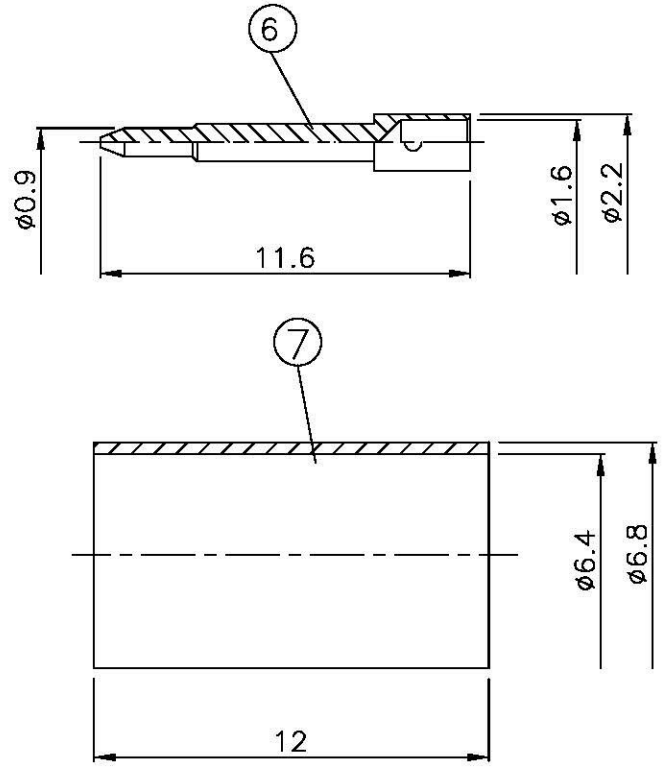
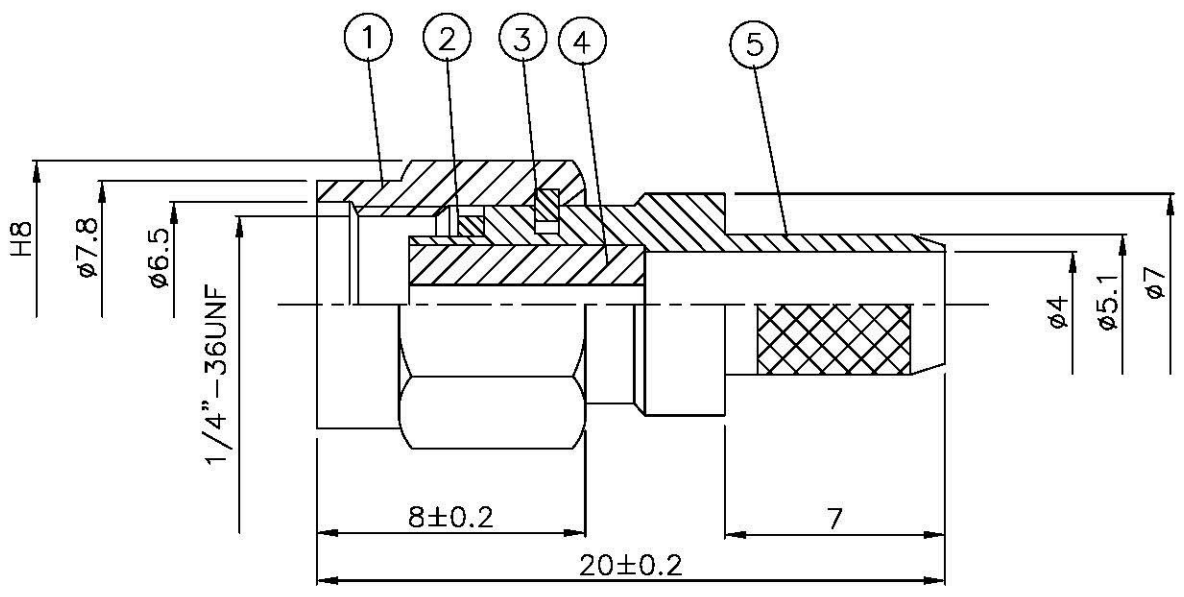
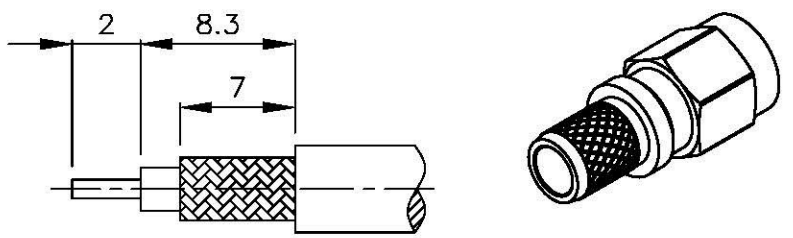

All Connectors
 www.allconnectors.de
 info@allconnectors.de
 70724 Filzschlitz - Germany
 70724 Filzschlitz - Germany

TITLE SMA MALE CRIMP FOR LMR-240

PART NO. SMA-03R-TGN

DRAWING NO. SMA-03R-TGN

DRAWN MARY	DATE 93.09.10
CHECKED 黄巧君	DATE 93.09.10
Q.A. 蘇姿潔	DATE
APPROVAL 徐燦霖	DATE
REVISION	DATE

DIMENSIONS ARE IN MILLIMETERS			
UNLESS OTHERWISE SPECIFIED TOLERANCES			
0.5-5=±0.2	120-315=±1		
5-30=±0.4	315-1000=±1.6		
30-120=±0.6	1000-2000=±2.4		
SCALE 4:1	SIZE A		

REVISION	
DESCRIPTION	ENGINEER