

NO	DESCRIPTION	MATERIAL	Q'TY	FINISH	REMARK
1	SHELL	BRASS	1	GOLD	B-SMA0043-G
2	GASKET	SI RUBBER	1	RUBBER	RU-0008
3	INSULATION	TEFLON	1	TEFLON	I-0115T
4	WASHER	PH.BRONZE	1	GOLD	W-0012
5	BODY 1	BRASS	1	GOLD	B-SMA0208-G
6	PIN	BRASS	1	GOLD	P-SMA0119-G
7	INAULATION 2	TEFLON	1	TEFLON	I-0229T
8	BODY 2	BRASS	1	GOLD	B-SMA0473-G

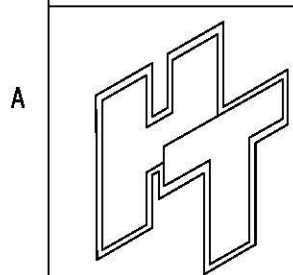
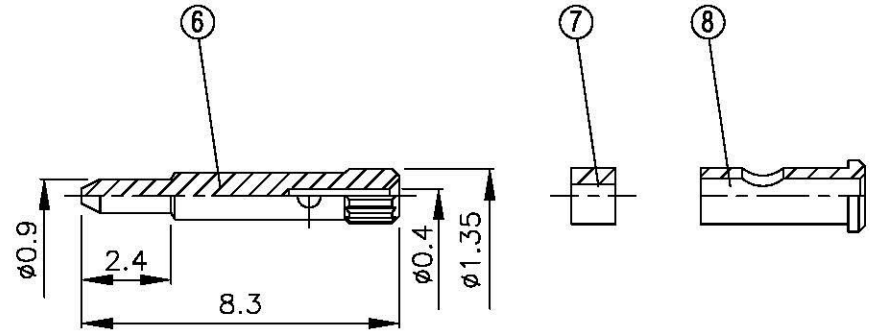
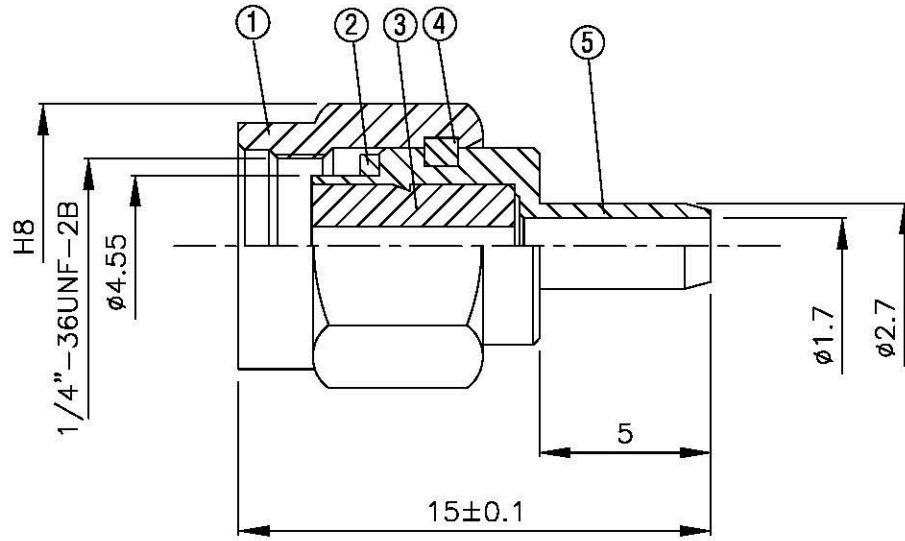
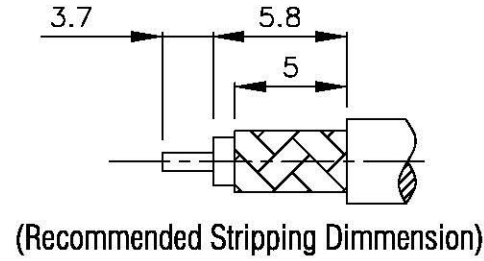

All Connectors

www.allconnectors.de
Tel: 0049 030 700500
70794 Filderstadt Germany

info@allconnectors.de
Tel: 0049 030 700504
Kettelerstr. 25

TITLE SMA MALE CRIMP FOR
RG 178/U

PART NO. SMA-03M-TGG

DRAWING NO. SMA 03M TGG

DRAWN MARY DATE 96.03.19

CHECKED 蘇志欣 DATE 97.05.20

Q.A. 蘇姿潔 DATE

APPROVAL 徐燦霖 DATE

REVISION DATE

DIMENSIONS ARE IN MILLIMETERS

UNLESS OTHERWISE SPECIFIED
TOLERANCE

0.5-5=±0.2 120-315=±1

5-30= ±0.4 315-1000=±1.6

30-120±0.6 1000-2000=±2.4

SCALE 4:1 SIZE A

REVISION

DESCRIPTION	ENGINEER

D

D

C

C

B

B

A

A

4

3

2

1