

NO	DESCRIPTION	MATERIAL	Q'TY	FINISH	REMARK
1	SHELL	BRASS	1	GOLD	B-SMA00421-G
2	GASKET	SI RUBBER	1	RUBBER	RU-0008
3	INSULATION	TEFLON	1	TEFLON	I-0115T
4	WASHER	PH.BRONZE	1	GOLD	W-0012
5	BODY	BRASS	1	GOLD	B-SMA0046-G
6	PIN	BRASS	1	GOLD	P-SMA0037-G
7	RING	BRASS	1	GOLD	R-0007-G

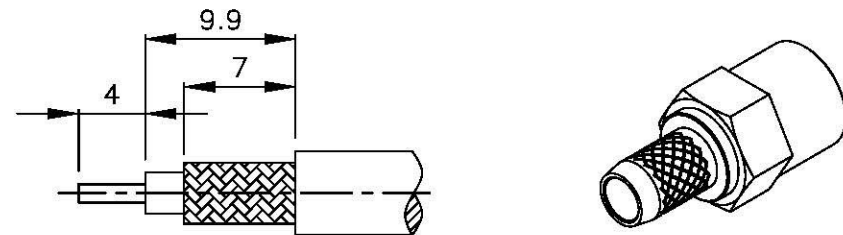

(Recommended Stripping Dimension)

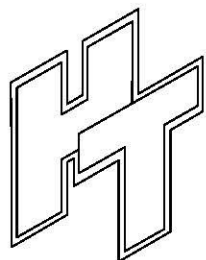
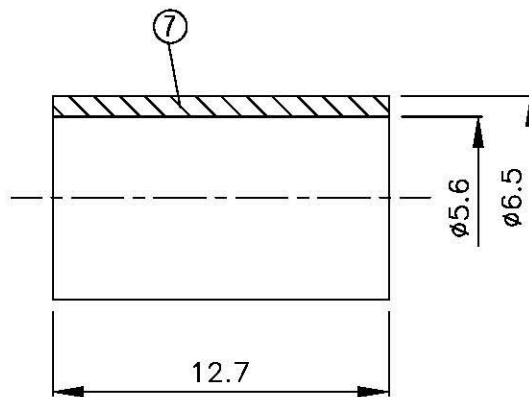
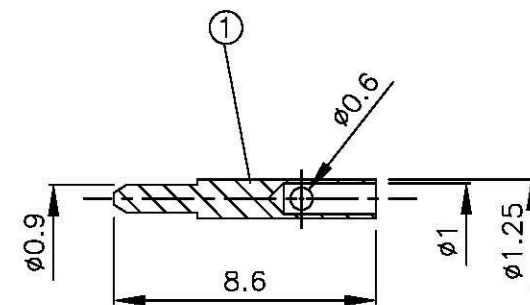
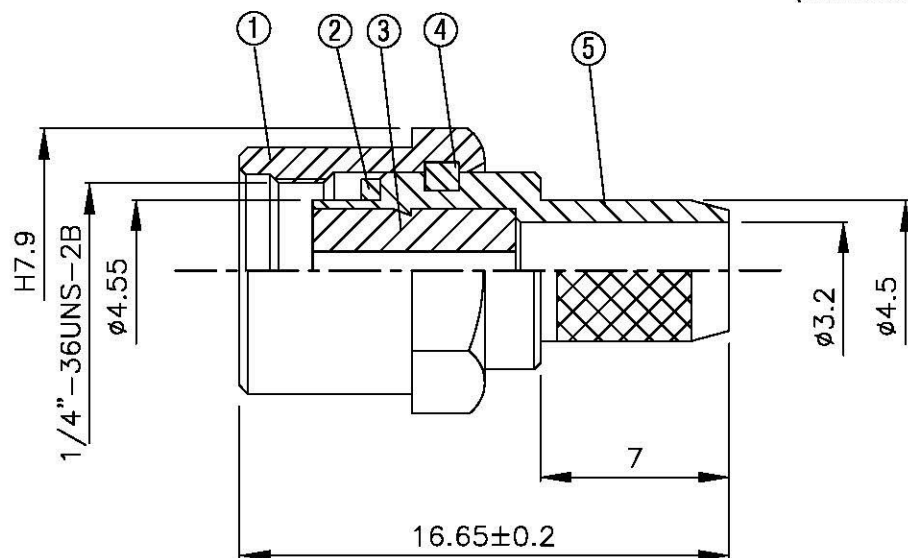

Allconnectors
 www.allconnectors.de
 Tel.: 0049 711 7002503
 30/34 Hildenerstr. Germany
 info@allconnectors.de
 Fax: 0049 711 7002504
 Kettenerstr. 25

TITLE SMA MALE CRIMP FOR RG58U,141A/U

PART NO. SMA-03FV1-TGG

DRAWING NO. SMA-03FV1-TGG

DRAWN MARY DATE 96.06.21

CHECKED 蘇志欣 DATE

Q.A. 蘇姿潔 DATE

APPROVAL 徐燦霖 DATE

REVISION DATE

DIMENSIONS ARE IN MILLIMETERS

UNLESS OTHERWISE SPECIFIED TOLERANCE
 0.5-5=±0.2 120-315=±1
 5-30=±0.4 315-1000=±1.6
 30-120±0.6 1000-2000=±2.4

SCALE 4:1 SIZE A

REVISION

DESCRIPTION ENGINEER