

NO	DESCRIPTION	MATERIAL	Q'TY	FINISH	REMARK
1	SHELL	BRASS	1	NICKEL	B-SMA0043-N
2	GASKET	SI RUBBER	1	RUBBER	RU-0008
3	INSULATION	TEFLON	1	TEFLON	I-0115T
4	WASHER	PH.BRONZE	1	GOLD	W-0012
5	BODY	BRASS	1	NICKEL	B-SMA0046-N
6	PIN	BRASS	1	GOLD	P-SMA0037-G
7	RING	BRASS	1	NICKEL	R-0047-N

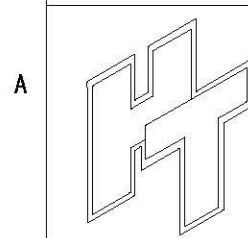
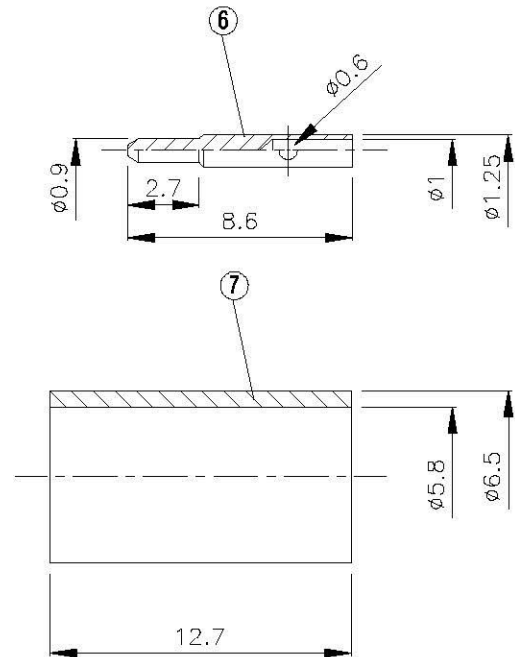
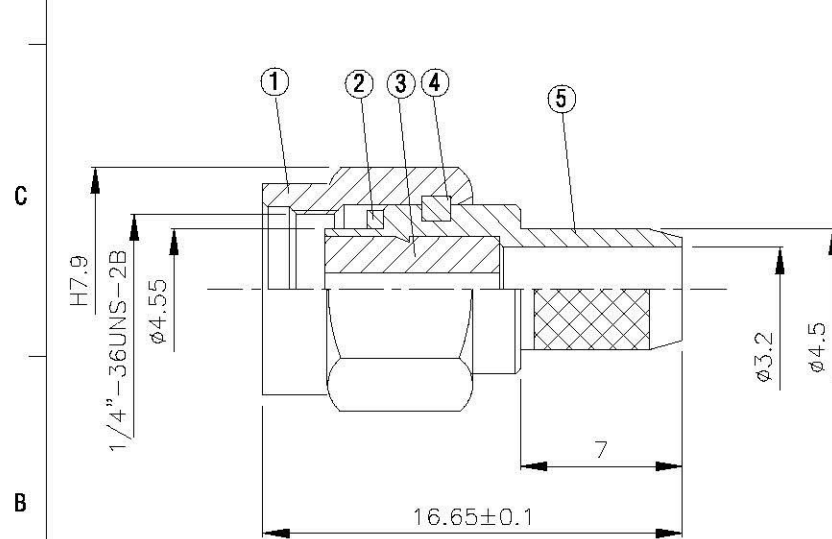
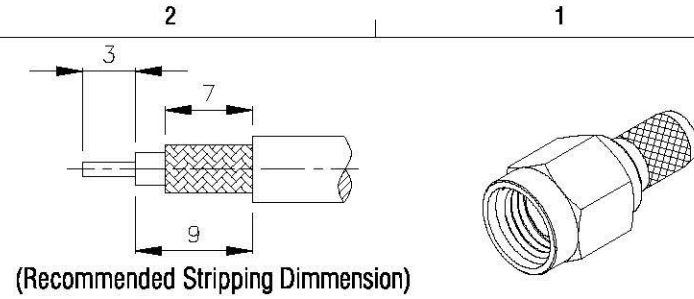

All Connectors
 www.allconnectors.de
 info@allconnectors.de
 42699 Solingen, Germany
 42699 Solingen, Germany
 0212 6491-0

TITLE SMA MALE CRIMP
FOR RG 400/U, 142/U

PART NO. SMA-03FA-TGN

DRAWING NO. SMA 03FA TGN

DRAWN MARY
CHECKED 黄巧君
Q.A. 蘇姿潔
APPROVAL 徐煉霖
REVISION

DATE 95.11.01

DATE

DATE

DATE

DATE

DIMENSIONS ARE IN MILLIMETERS

UNLESS OTHERWISE SPECIFIED TOLERANCE

0.5-5=±0.2	120-315=±1
5-30=±0.4	315-1000=±1.6
30-120=±0.6	1000-2000=±2.4

SCALE 4:1 **SIZE** A

REVISION	
DESCRIPTION	ENGINEER