

NO	DESCRIPTION	MATERIAL	Q'TY	FINISH	REMARK
1	SHELL	BRASS	1	GOLD	B-SMA0043-G
2	GASKET	SI RUBBER	1	GOLD	RU-0008
3	WASHER	PH.BRONZE	1	GOLD	W-0012-G
4	INSULATION	TEFLON	1	TEFLON	I-0138T
5	PIN	BRASS	1	GOLD	P-SMA0065-G
6	BODY	BRASS	1	GOLD	B-SMA0486-G
7	INSULATION	TEFLON	1	TEFLON	I-0136T
8	WASHER	GOLD	1	GOLD	W-0023-G
9	BODY	BRASS	1	GOLD	B-SMA0154-G

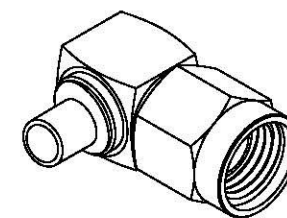

(Recommended Stripping Dimension)

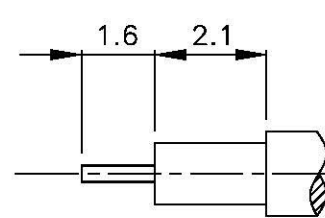
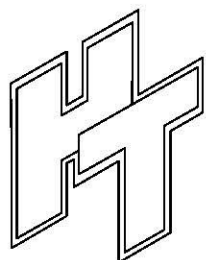
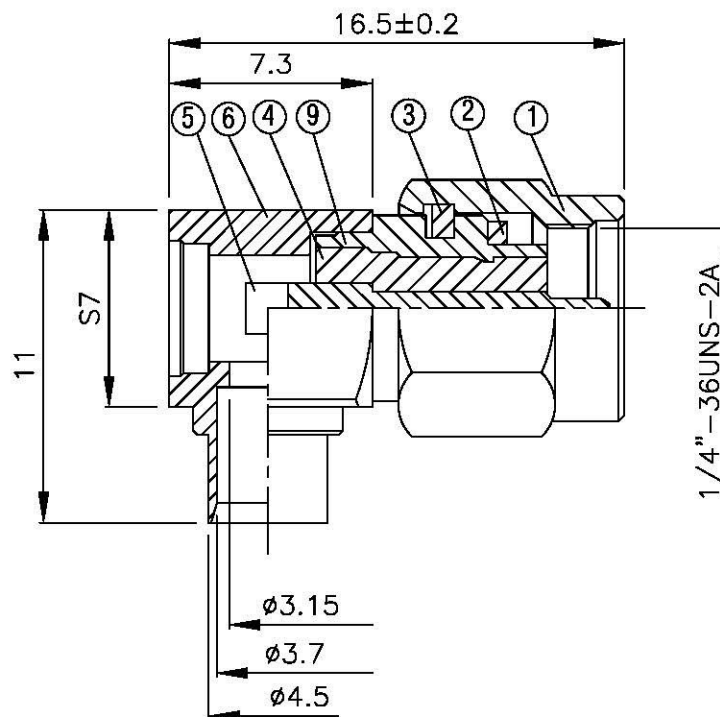
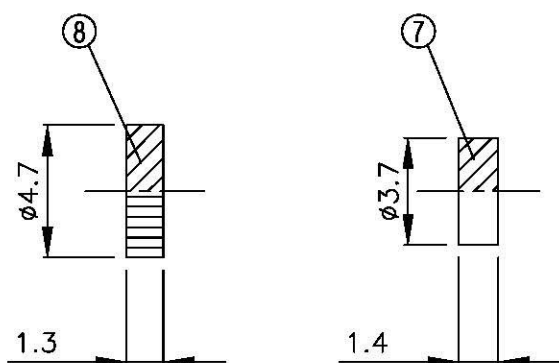

Allconnectors

www.allconnectors.de
Tel.: 0049 711 2009503
Jülich-Hilberstadt - Germany

info@allconnectors.de
Fax: 0049 711 2009504
Kettmeistr. 25

TITLE
SMA MALE SLIDER FOR RG 402 (.141)

PART NO.
SMA-02V2-TGG

DRAWING NO. SMA 02V2 TGG

DRAWN MARY DATE 95.11.01

CHECKED 黄巧君 DATE

Q.A. 蘇姿潔 DATE

APPROVAL 徐燦霖 DATE

REVISION DATE

DIMENSIONS ARE IN MILLIMETERS

UNLESS OTHERWISE SPECIFIED
TOLERANCE

0.5-5=±0.2 120-315=±1

5-30=±0.4 315-1000=±1.6

30-120±0.6 1000-2000=±2.4

SCALE 4:1 SIZE A

REVISION

DESCRIPTION ENGINEER

D

C

B

A

D

C

B

A

4

3

2

1