

NO	DESCRIPTION	MATERIAL	Q'TY	FINISH	REMARK
1	BODY	BRASS	1	NICKEL	B-SMA0155-N
2	BODY	BRASS	1	NICKEL	B-SMA0145-N
3	INSULATION	TEFLON	1	TEFLON	I-0198T
4	PIN	BRASS	1	GOLD	P-SMA0817-G
5	RING	BRASS	1	NICKEL	R-0002-N
6	NUT	BRASS	2	GOLD	N-0006-N
7	WASHER	BRASS	2	GOLD	W-0016-N
8	WASHER	BRASS	1	GOLD	W-0023-N
9	INSULATION	TEFLON	1	TEFLON	I-0136T

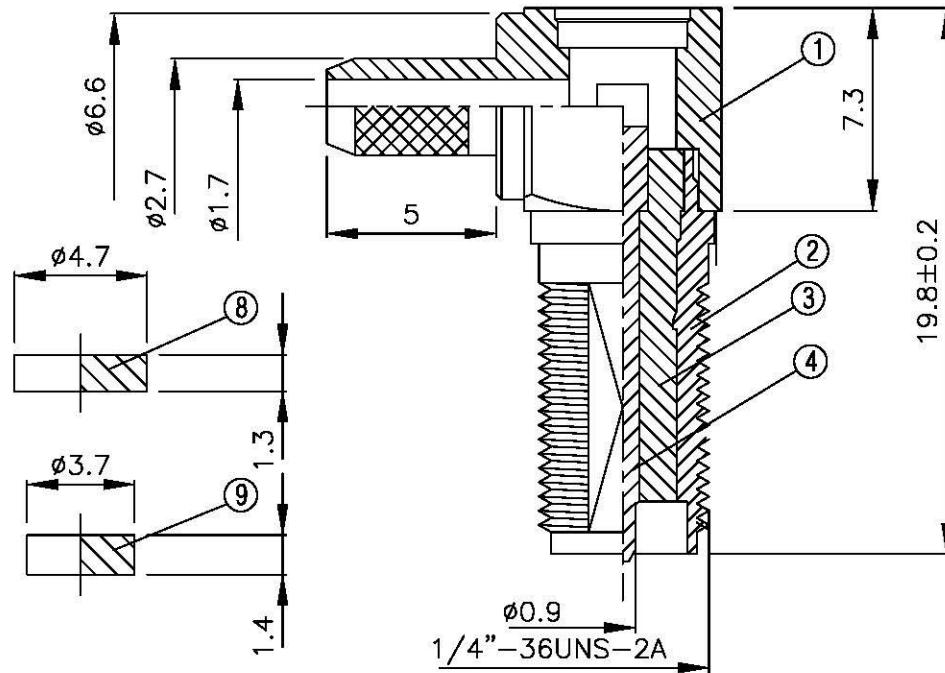
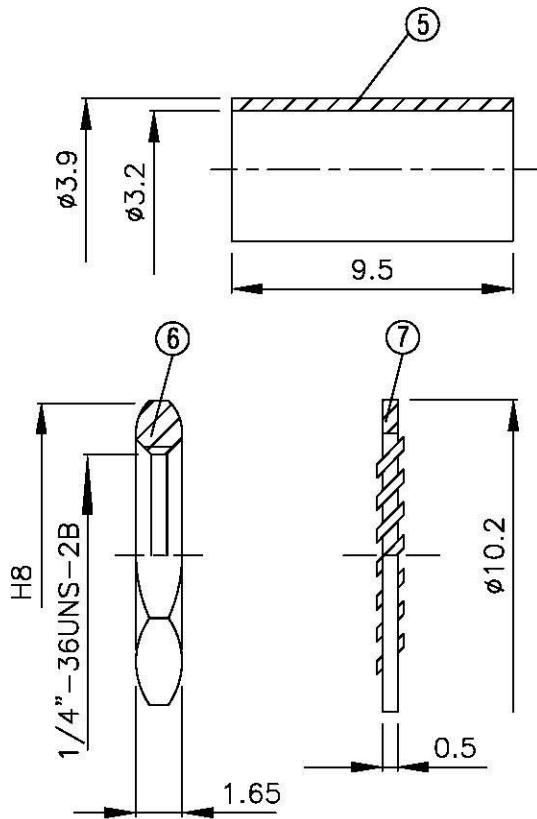
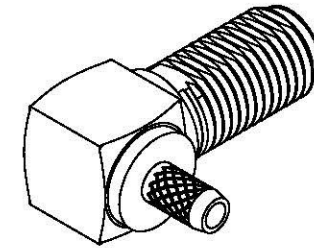
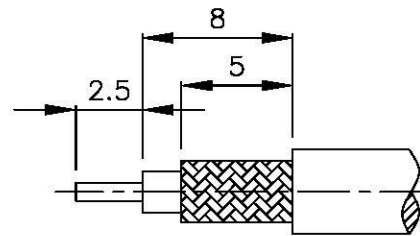

All Connectors
 www.allconnectors.de
 Tel.: 0049 211 7009509
 info@allconnectors.de
 Fax: 0049 211 7009504
 70729 Hildersrieden - Germany
 info@allconnectors.de
 Fax: 0049 211 7009504
 70729 Hildersrieden - Germany

TITLE SMA FEMALE CRIMP FOR RG 174U REVERSE POLARITY

PART NO. SMA-93LV1-TGN-RP

DRAWING NO. SMA 93LV1 TGN RP

DRAWN	MARY	DATE	96.02.12
CHECKED	黄巧君	DATE	
Q.A.	蘇姿潔	DATE	
APPROVAL	徐燦霖	DATE	
REVISION		DATE	

DIMENSIONS ARE IN MILLIMETERS			
UNLESS OTHERWISE SPECIFIED TOLERANCE			
0.5-5=±0.2	120-315=±1		
5-30=±0.4	315-1000=±1.6		
30-120±0.6	1000-2000=±2.4		
SCALE	4:1	SIZE	A

REVISION	
DESCRIPTION	ENGINEER