

NO	DESCRIPTION	MATERIAL	Q'TY	FINISH	REMARK
1	NUT	BRASS	1	NICKEL	N-0006
2	WASHER	BRASS	1	NICKEL	W-0016
3	GASKET	SI RUBBER	1	RUBBER	RU-0014
4	INSULATION	TEFLON	1	TEFLON	I-0524T
5	BODY	BRASS	1	NICKEL	B-SMA1087-N
6	PIN	BE CU	1	GOLD	P-SMA0868-G
7	RING	BRASS	1	NICKEL	B-SMA0473-N
8	INSULATION2	TEFLON	1	TEFLON	I-0256T

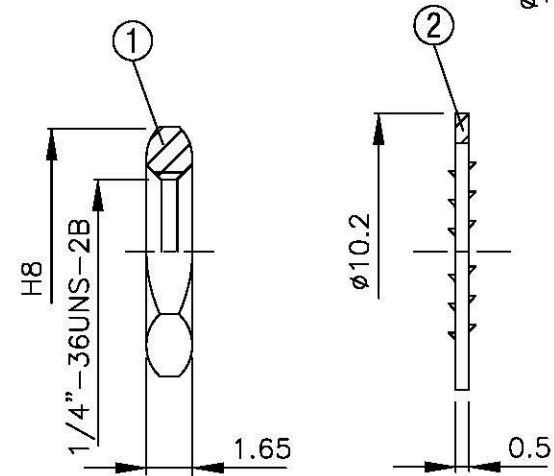
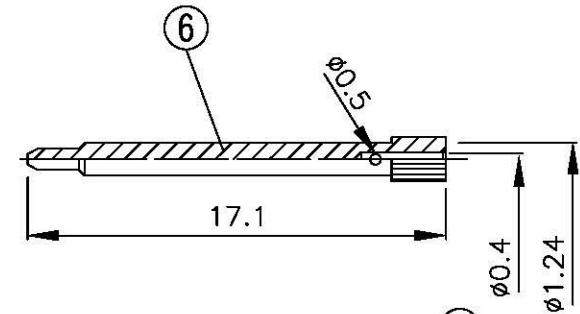
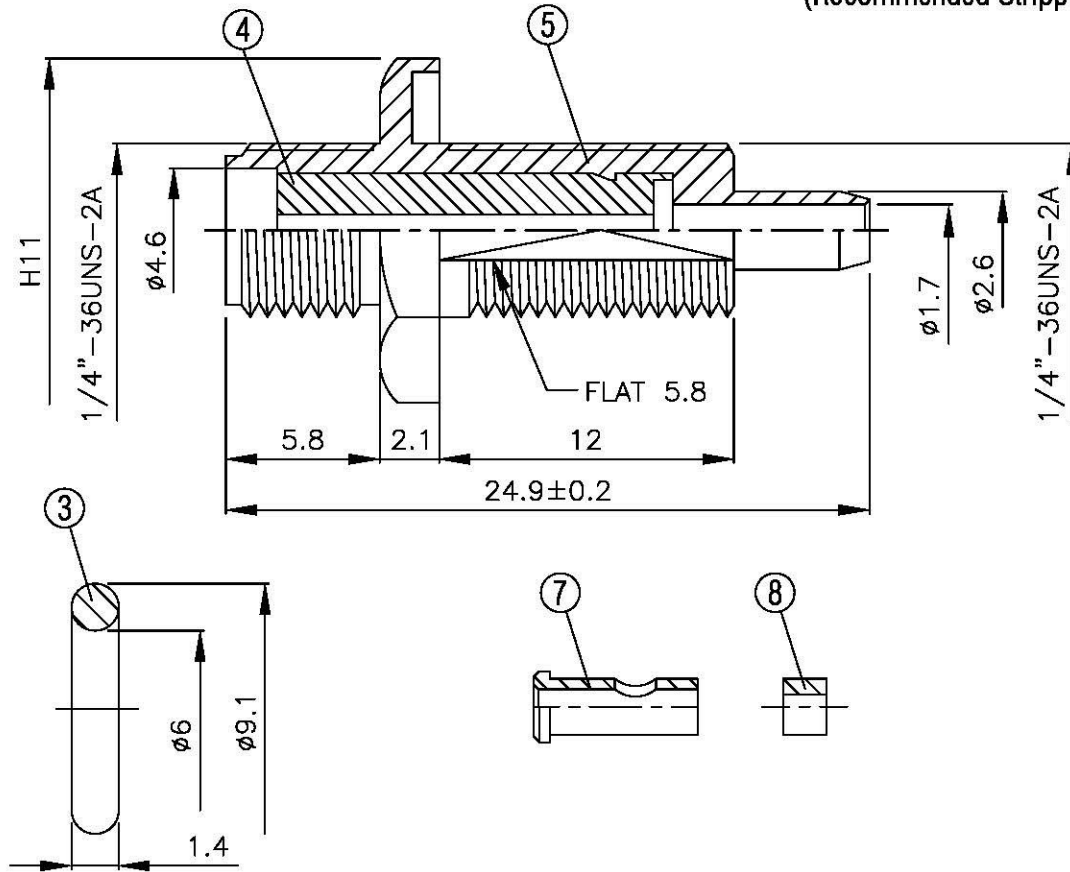
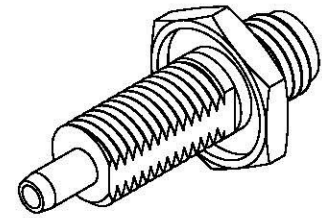
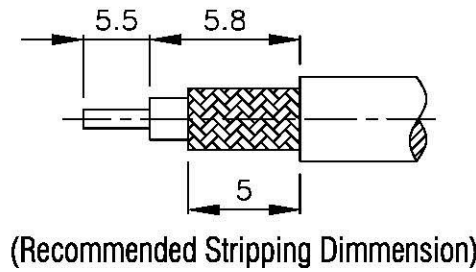

	All Connectors <small>www.allconnectors.de Tel.: 0049 711 7600503 76734 Nidersach - Germany</small>	DRAWN MARY CHECKED 蘇姿潔 Q.A. 馮健華 APPROVAL 徐燦霖 REVISION	DATE 96.08.10 DATE DATE DATE	DIMENSIONS ARE IN MILLIMETERS UNLESS OTHERWISE SPECIFIED TOLERANCE 0.5-5=±0.2 120-315=±1 5-30=±0.4 315-1000=±1.6 30-120±0.6 1000-2000=±2.4	REVISION	
	TITLE SMA FEMALE CRIMP FOR RG-178/U PART NO. SMA-91M-TGN-RP DRAWING NO. SMA 91M TGN RP	DESCRIPTION ENGINEER	A			
	SCALE 4:1 SIZE A					