

NO	DESCRIPTION	MATERIAL	Q'TY	FINISH	REMARK
1	NUT	BRASS	1	NICKEL	N-0006
2	WASHER	BRASS	1	NICKEL	W-0016
3	INSULATION	TEFLON	1	TEFLON	I-0131T
4	BODY	BRASS	1	NICKEL	B-SMA0506-N
5	PIN	BRASS	1	GOLD	P-SMA0059-G
6	RING	BRASS	1	NICKEL	R-0002

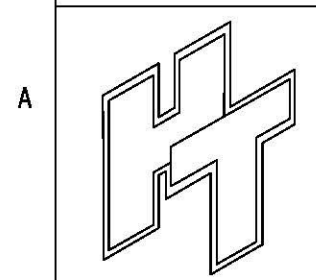
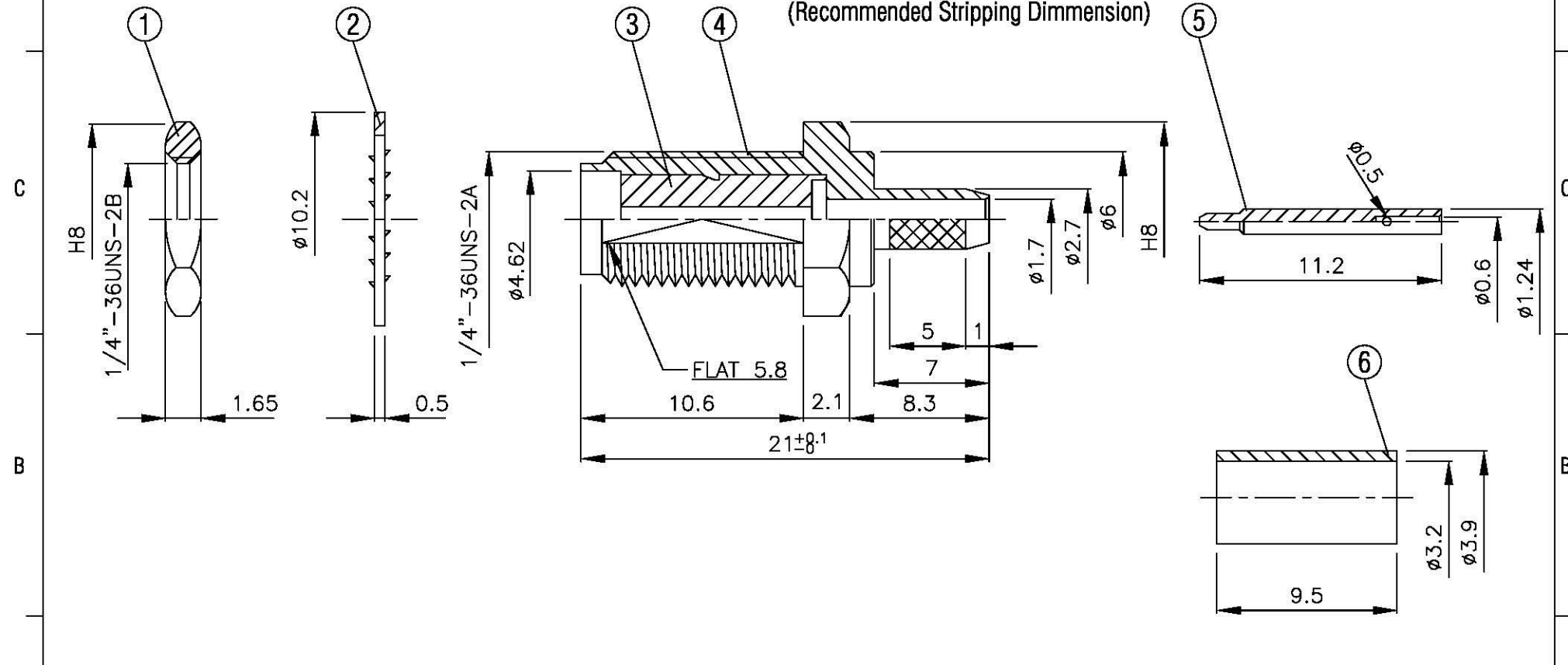
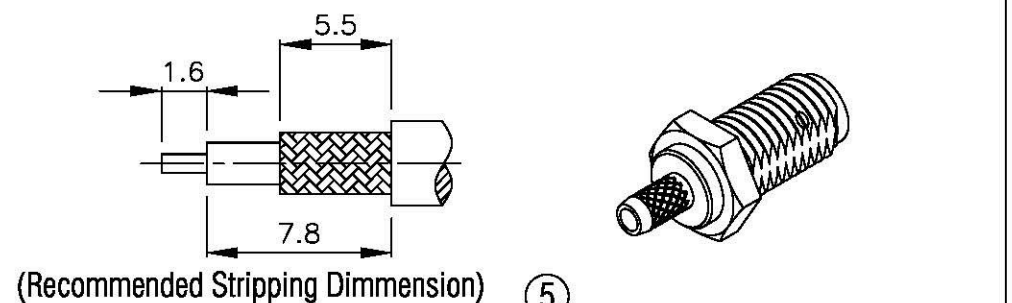

**All Connectors**  
 www.allconnectors.de  
 Tel.: 0049 711 7000503  
 70704 Filderstadt - Germany  
 info@allconnectors.de  
 Fax: 0049 711 7000504  
 Kastnerstr. 25

**TITLE** SMA FEMALE CRIMP FOR RG 174/U (REVERSE POLARITY)  
**PART NO.** SMA-56LV1-TGN-RP  
**DRAWING NO.** SMA 56LV1 TGN-RP

<b>DRAWN</b>	MARY	<b>DATE</b>	92.05.06
<b>CHECKED</b>	黃巧君	<b>DATE</b>	92.05.06
<b>Q.A.</b>	蘇姿潔	<b>DATE</b>	
<b>APPROVAL</b>	徐燦霖	<b>DATE</b>	
<b>REVISION</b>		<b>DATE</b>	

<b>DIMENSIONS ARE IN MILLIMETERS</b>			
UNLESS OTHERWISE SPECIFIED TOLERANCE			
0.5-5=±0.2	120-315=±1		
5-30=±0.4	315-1000=±1.6		
30-120±0.6	1000-2000=±2.4		
<b>SCALE</b>	4:1	<b>SIZE</b>	A

<b>REVISION</b>	
<b>DESCRIPTION</b>	<b>ENGINEER</b>