

NO	DESCRIPTION	MATERIAL	Q'TY	FINISH	REMARK
1	PIN	BRASS	1	GOLD	P-SMA0223-G
2	BODY 1	BRASS	1	NICKEL	B-SMA0233-N
3	NUT 1	BRASS	1	NICKEL	N-0020-N
4	INSULATION 1	TEFLON	1	TEFLON	I-0047T
5	BODY 2	BRASS	1	NICKEL	B-SMA0232-N
6	INSULATION 2	TEFLON	1	TEFLON	I-0171T
7	WASHER	BRASS	1	NICKEL	W-0016-N
8	NUT 2	BRASS	1	NICKEL	N-0006-N
9	RING	BRASS	1	NICKEL	R-0002-N

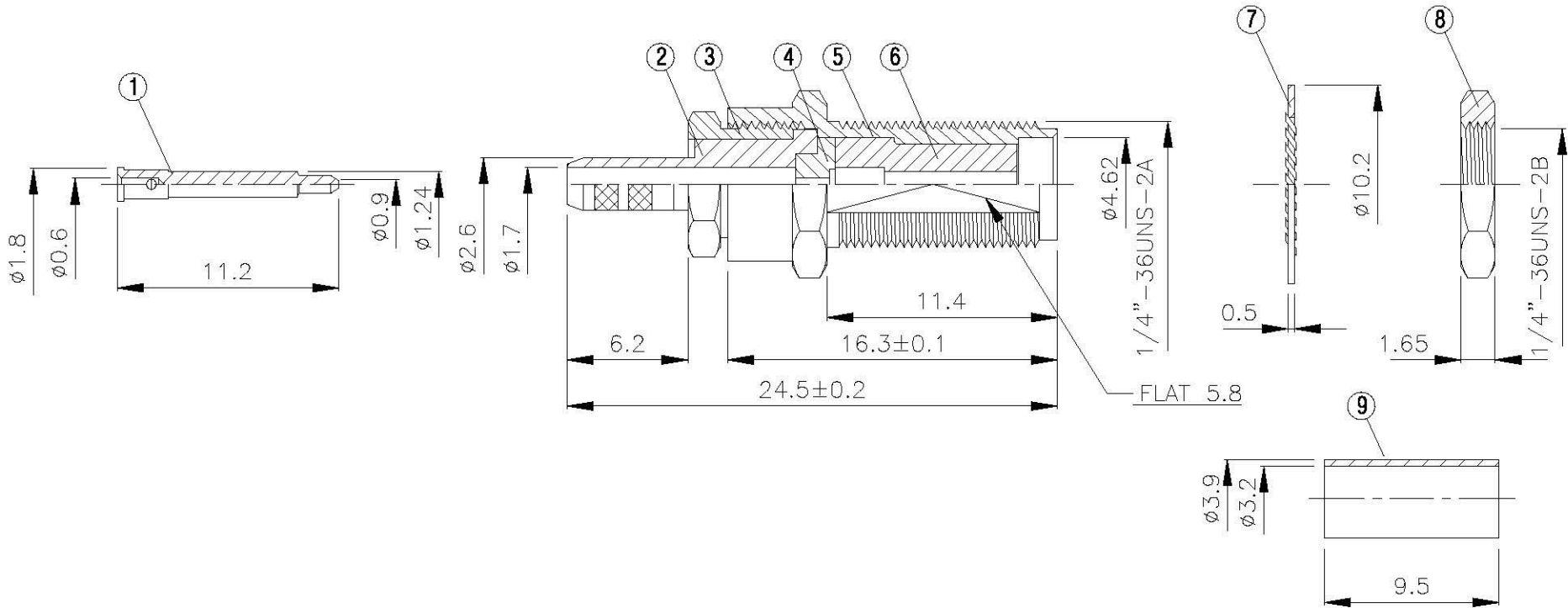
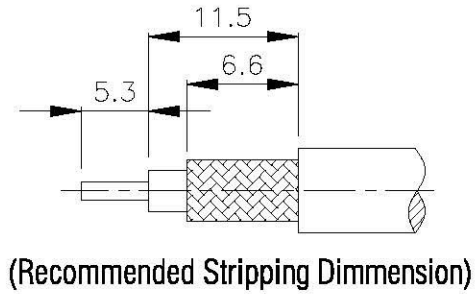

	All Connectors <small>www.allconnectors.de Tel.: 0049 711 7009503 70724 Filderstadt - Germany</small>	DRAWN MARY CHECKED 蘇志欣 Q.A. 蘇姿潔 APPROVAL 徐燦霖 REVISION	DATE 91.10.08 DATE DATE DATE	DIMENSIONS ARE IN MILLIMETERS UNLESS OTHERWISE SPECIFIED TOLERANCE 0.5-5=±0.2 120-315=±1 5-30=±0.4 315-1000=±1.6 30-120±0.6 1000-2000=±2.4	REVISION	
	TITLE SMA FEMALE CRIMP FOR RG316U (REVERSE POLARITY)	APPROVAL 蘇姿潔	DATE	SCALE 4:1 SIZE A	DESCRIPTION	ENGINEER
	PART NO. SMA-44LV1-TGN-RP	APPROVAL 徐燦霖	DATE			
	DRAWING NO. SMA-44LV1-TGN-RP	REVISION	DATE			