

NO	DESCRIPTION	MATERIAL	Q'TY	FINISH	REMARK
1	SHELL	BRASS	1	GOLD	B-SMA0043-G
2	GASKET	SI RUBBER	1	RUBBER	RU-0008
3	INSULATION	TEFLON	1	TEFLON	I-0235T
4	WASHER	PH.BRONZE	1	GOLD	W-0012
5	BODY	BRASS	1	GOLD	
6	PIN	BE CU	1	GOLD	
7	INSULATION	TEFLON	1	TEFLON	I-0347T
8	BODY	BRASS	1	GOLD	B-SMA0473-G

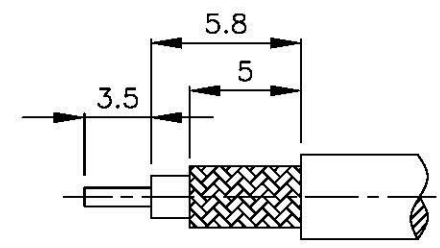

(Recommended Stripping Dimension)

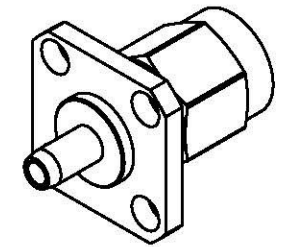

D

D

PIN CHUCK
0.2x2x2 GROOVE

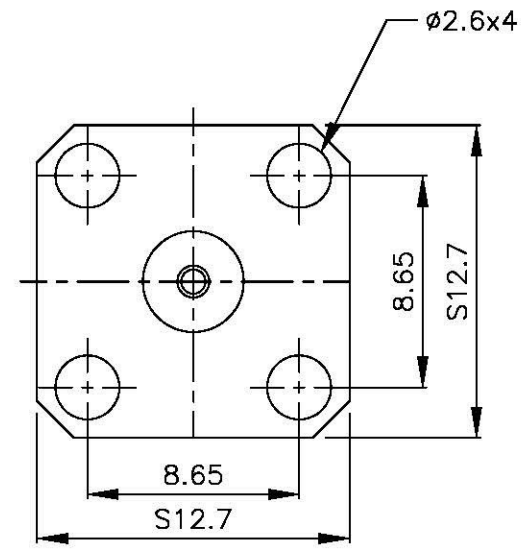
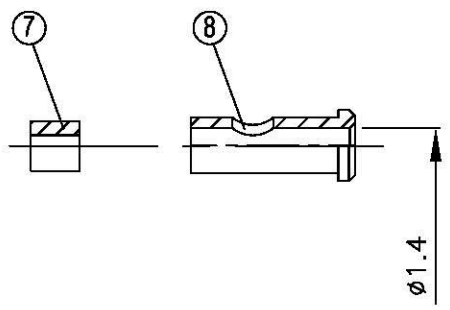
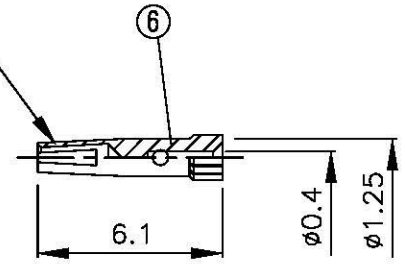

C

C

B

B

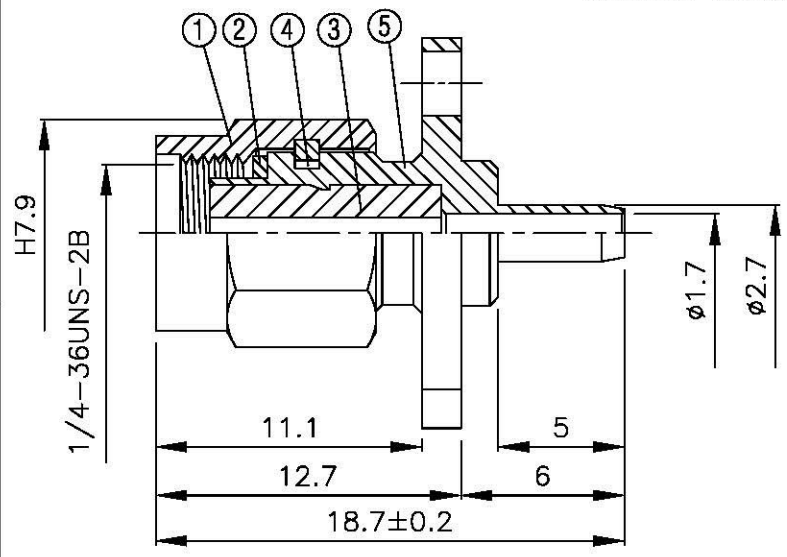

A

A

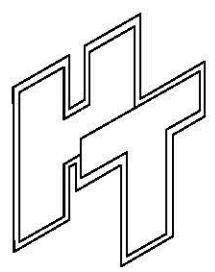

Allconnectors
 www.allconnectors.de
 info@allconnectors.de
 TEL: 0049 711 7003005
 FAX: 0049 711 7003004
 39144 Hilsbergstr. Germany

TITLE SMA MALE PANEL CRIMP
FOR RG 178/U(REVERSE POLARITY)

PART NO. SMA-33M-TGG-RP

DRAWING NO. SMA 33M TGG RP

DRAWN MARY	DATE 96.03.15
CHECKED 黄巧君	DATE
Q.A. 蘇姿潔	DATE
APPROVAL 徐燦霖	DATE
REVISION	DATE

DIMENSIONS ARE IN MILLIMETERS			
UNLESS OTHERWISE SPECIFIED TOLERANCE			
0.5-5=±0.2	120-315=±1		
5-30=±0.4	315-1000=±1.6		
30-120±0.6	1000-2000=±2.4		
SCALE 4:1	SIZE A		

REVISION	
DESCRIPTION	ENGINEER

4

3

2

1